



TRIKE CONVERSION KIT

2009 - CURRENT

FLHT SERIES HARLEY-
DAVIDSON

INSTALLATION
INSTRUCTIONS

REVISED 1 - 2012

CALIFORNIA SIDECAR PARTS & TECHNICAL SUPPORT
434.263.8866

Table of contents:

1. Warnings and Considerations	3
2. General Information	4
3. Maintenance Schedule	5
4. Disassembly of Motorcycle	6
5. Front Drive Belt Installation	9
6. Modification of Frame	12
7. Rear Suspension Unit Installation	13
8. Brake Line Installation	15
9. Bleeding the Brake System	17
10. Gravel Pan Installation	18
11. Exhaust Mount Installation	18
12. Exhaust Installation	19
13. Link to CSC Belt Tensioning video	20
14. Setting up the Sonic Tension Meter	20
15. Using the Sonic Tension Meter	20
16. Tensioning the Front Drive Belt	21
17. Tensioning the Rear Drive Belt	22
18. Service limits on Drive Belts	23
19. Suspension Setup	24
20. Trike Body Installation	26
21. Tour Pak Installation	26
22. Trike Body Alignment	27
23. Securing the Trike Body	28
24. Reassembly of the Motorcycle	29
25. Final Reassembly of the Motorcycle	29

Warnings and considerations:

1. **Disclaimer** - These instructions assume a level of understanding of motorcycle repair and maintenance beyond that of a “beginner” and/or “novice” and California Sidecar cannot be liable for an installer’s failure to understand or follow these instructions as written. Likewise, California Sidecar cannot be responsible if any of the steps are omitted or shortcuts are taken, or parts other than those supplied by California Sidecar, are used in installing this trike kit.
2. **“WARNINGS”** are all printed in bold type and capitalized. They mean to use extreme care in a given step so as not to damage the part, motorcycle, and/or yourself.
3. **Always** wear safety glasses when using hand and/or power tools.
4. When working in and around the fuel system, **always** work in a well-ventilated area, free from sparks and open flames.
5. All directional references to the “right side” and the “left side” are as you were seated on the motorcycle.
6. All directional references to “forward” mean to the front of the motorcycle while “back” means the rear of the motorcycle unless otherwise stated.
7. Please consult the appropriate Service Manual for your motorcycle if further detail is necessary.

Recommended Lubricants and Sealants:

- 1. Molybdenum Disulfide grease for splines (Mobil Grease Moly 52 or equivalent)**
- 2. Multipurpose grease for Zerk fittings.**
- 3. Thread locking compound (Loctite 242 minimum).**
- 4. High temperature Silicone sealant.**

Torque values of fasteners:

- 1. Rear Fork Pivot Shaft Nut 40 – 45 ft/lbs**
- 2. 7/16 – 14 x 1 ½ hex head cap screw 38 – 42 ft/lbs**
- 3. 3/8–16 x 1 button head cap screw for the upper mount
12 ft/lbs**
- 4. 3/8–16 nyloc nut on the rear suspension studs 12
ft/lbs**
- 5. 1/2 - 13 x 2 hex head cap screw 75 ft/lbs**
- 6. 7/16 – 20 x 1 ½ hex head cap screw 38 – 42 ft/lbs**

Acronyms of fasteners:

- 1. HHCS = Hex head cap screw**
- 2. SHCS = Socket head cap screw**

Maintenance Schedule: DAYTONA

Frequency (miles)	Daily	4k	8k	12k	16k	20k	24k
Item							
Belts	I	I	I	I	I	T	I
Brake Pads and Rotors [1]		I	I	I	I	I	I
Half Shaft Boots		L	L	L	L	L	L
Wheel Bearings [2]		I	I	I	I	I	I
Wheels and Tires		I	I	I	I	I	I
All Lighting	I						
Tire Pressure [3]	I						
Brake fluid		I	I	R	I	I	R

I: Inspect: clean, lubricate, and/or replace as necessary.

R: Replace

L: Lubricate with Silicone Spray

T: Tension

NOTE:

[1] Minimum pad thickness is 0.04 inches (1.02mm)

[2] Wheel bearing torque 200 FT.-LBS.

[3] Rear tire pressure 28 PSI

At higher odometer readings, repeat at frequency intervals established here.

Note:

This Schedule is in addition to the Harley Davidson Maintenance Schedule

NOTICE:

The remote door opener installed on this unit has a very small electrical draw on your motorcycle battery. If your trike will be unriden for more than 2 weeks you should remove the 15 amp fuse from the red fuse holder located under your seat or right side cover. Another option is using a battery tender.

Disassembly of motorcycle:

- 1. Place the motorcycle on the lift.**
- 2. Place a suitable Jack under the Frame of the Motorcycle and tie down securely.**
- 3. Remove Drain Plug from Primary Cover Assembly and drain oil.**
- 4. Slide Rubber Boot off of the Clutch Cable Adjuster. Loosen and back the Jam nut away from the Clutch Cable Adjuster. Move Clutch Cable Adjuster towards the Jam Nut to introduce free play in the Clutch Lever.**
- 5. Remove the $\frac{1}{4}$ - 20 Phillips head screw and Seat.**
- 6. Disconnect and REMOVE battery.**
- 7. Remove two $\frac{1}{4}$ - 20 flanged hex nuts from the Stud Plate. Remove and save the Passenger Handrail and two $\frac{1}{4}$ - 20 flanged hex head nuts if equipped.**
- 8. Remove the Saddle Bags.**
- 9. Remove the Right and Left Side Covers.**
- 10. Remove Inner Tour Pak Molded Liner.**
- 11. Disconnect the Tour Pak wiring.**
- 12. Remove four $\frac{1}{4}$ - 20 HHCS.**
- 13. Remove Tour Pak from Top Support Tube.**
- 14. Remove both saddlebag support rails.**
- 15. Loosen Muffler Clamps on both Mufflers and remove two $\frac{5}{16}$ - 18 HHCS per Muffler. Remove and discard both Mufflers. Save Muffler Clamps.**
- 16. Remove right side rear heat shield.**
- 17. Remove and discard Muffler Support Plates.**
- 18. Disconnect the Rear Lamp Wiring Harness and remove from T-stud Clip.**
- 19. Remove four frame cover fasteners and the Left and Right Frame Covers.**
- 20. Remove four Tour Pak Support fasteners and the Tour Pak Support.**

21. Remove four rear fender fasteners and rear fender.
 22. Remove four $\frac{1}{2}$ - 13 HHCS and washers. Remove and discard Rear Air Shocks, Air lines and Air Valve bracket.
 23. **NOTE:** If motorcycle is A.B.S. Equipped refer to A.B.S. Installation Instructions.
- WARNING:** If A.B.S. Equipped DO NOT drain brake fluid.
24. Drain all Brake Fluid from the Rear Brake System.
 25. Cut and remove Cable ties and un-clamp Wire Harness Loops from the Rear Brake Line along its length, including Clamps on Swing Arm.
 26. Remove and discard Banjo Bolt and Crush Washers on Rear Brake Caliper.
 27. Remove the Spring Clip and nut from the Rear Axle.
 28. Remove Rear Axle and Rear Wheel Spacers.
 29. Push Rear Wheel Assembly forward and slip Rear Belt off of the Rear Sprocket.
 30. Remove Rear Brake Caliper.
 31. Remove and save the two Retaining Washers from the Stud Plate. Remove and save the Stud Plate.
 32. Remove Rear Wheel Assembly.
 33. Remove two $\frac{3}{8}$ - 16 SHCS. Remove Passenger Footboards.
 34. Place a suitable Jack under the Oil Pan of the Transmission. Raise Jack to enable easy removal of the Rubber Mounts and Rear Fork Pivot Shaft.
 35. Remove two $\frac{7}{16}$ - 14 HHCS and washers. Remove Left Rear Fork Bracket.
 36. Remove Right Rear Fork Shaft Nut. Remove Cup Washer from Rear Fork Pivot Shaft.
 37. Remove Rear Fork Pivot Shaft.
 38. Remove and discard the Rear Fork.
 39. Remove Rear Fork Pivot Shaft Nut on the Left side of the Shaft. Remove the Cup Washer, Rubber Mount and Spacer. Discard Spacer and replace Rubber Mount and

- Cup Washer apply thread locking agent to the threads.
Reinstall the Swing Arm Pivot Shaft Nut. Torque to spec.
40. Remove two 3/8 – 16 SHCS. Remove the Left Driver Footboard.
 41. Remove the HHCS, flat washer, and lock washer and the lock plate from the top of the Jiffy Stand then remove the Jiffy Stand and its spring.
 42. Remove the Inner and Outer Shift Levers.
 43. Remove ten 1/4 - 20 SHCS. Remove the Primary Cover.
 44. Remove and discard Primary Cover Gasket.
 45. Clean residual gasket material from both surfaces.
 46. Remove the two fasteners and the Primary Chain Adjuster.
 47. Remove the Clutch Lifter Retaining Ring from the Clutch Basket. Remove Clutch Lifter Assembly.
 48. Using the Primary Drive Locking Tool. Place it into position and loosen the Compensating Sprocket Bolt.
 49. Using the Primary Drive Locking Tool. Place it into position and loosen the Clutch Hub Main shaft Nut. **WARNING:** This nut is **LEFT HAND** threaded.
 50. Remove the Clutch Assembly, Primary Chain, Compensating Sprocket, and Crank Shaft Extension in one assembly.
 51. Loosen but do not remove two 5/16 SHCS from the starter motor.
 52. Remove five 5/16 – 18 HHCS from the inside of the Primary Chain case. Remove the Primary Chain case.
 53. Remove the Crankcase gasket. Remove two white plastic tree clips from that gasket to be used on the new gasket.
 54. Remove the Final Drive Belt.

FRONT DRIVE BELT INSTALLATION:

- 1. Install new Front Drive Belt.**
- 2. Install new inner primary gasket with two white plastic tree clips saved from before.**
- 3. Reinstall the inner primary and its fasteners. Torque to the 25–27 FT-LBS in the sequence below.**

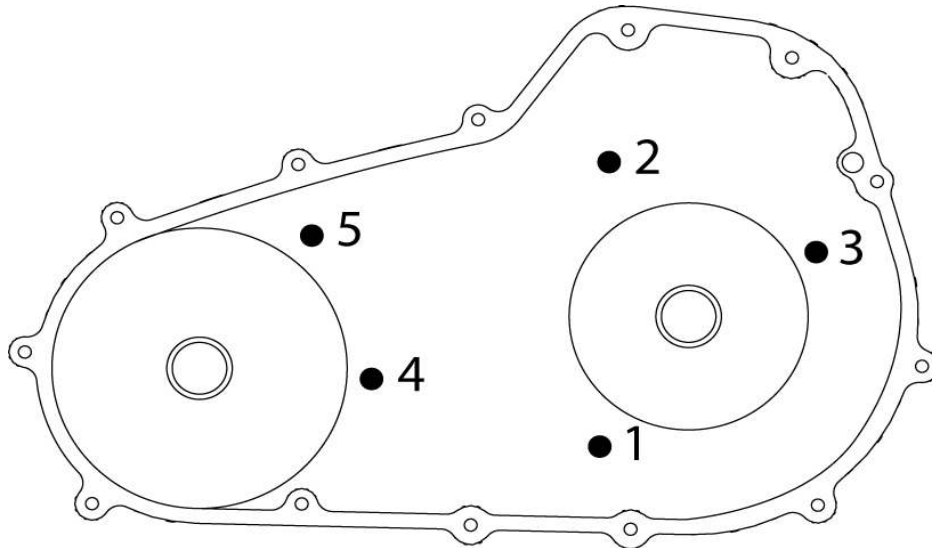

- 4. Place starter into position and tighten the two fasteners.**
- 5. Install the Clutch, Primary Chain, compensating Sprocket, and Shaft Extension as one assembly. Start the Clutch onto the Main Shaft first. Then align the splines of the Engine Sprocket Shaft with the splines in the Shaft Extension. Now align the splines in the Clutch with the splines on the Main Shaft.**
- 6. Clean off old Loctite then apply two drops of Loctite 262 to the threads of the Compensating Sprocket Bolt and Clutch Hub Main Shaft Nut.**
- 7. Install the Compensating Sprocket Bolt and hand tighten.**
- 8. Install the LEFT HAND threaded Clutch Hub Main Shaft Nut and hand tighten.**

9. Using the Primary Drive Locking Tool. Torque the Compensating Sprocket Bolt to 100 FT-LBS then loosen bolt one full turn. Then final torque is 140 FT-LBS.
10. Using the Primary Drive Locking Tool. Torque the Clutch Hub Nut to 70–80 FT-LBS. **WARNING:** This nut is **LEFT HAND** threaded.
11. Remove the Primary Drive Locking Tool.
12. Place the Clutch Release Plate into the Clutch with the stamped word “OUT” facing outwards.
13. Install the Retaining Ring into the bore of the Clutch Hub. Ensure the Retaining Ring is fully seated in to the Clutch Hub groove.
14. Loosen Lock Nut on the Clutch Adjuster Screw.
15. Turn the Clutch Adjuster Screw inwards until lightly seated.
16. Back out Clutch Adjuster Screw $\frac{1}{2}$ to 1 turn. While holding the Clutch Adjuster Screw from turning, tighten the Clutch Adjuster Screw Jam Nut to 72 – 120 in/lbs.
17. Squeeze the Clutch Lever 3 times to its maximum limits.
18. Move Clutch Cable Adjuster away from the Jam Nut to remove free play in the Clutch Lever. Adjust Clutch Cable free play until there is $\frac{1}{16}$ to $\frac{1}{8}$ inch gap between the Clutch Cable ferrule and Clutch Lever Bracket.
19. Tighten the Clutch Cable Adjuster Jam Nut. Slide the Rubber Boot over the Clutch Cable Adjuster.
20. Install the Primary Chain Adjuster with its fasteners and tighten.
21. Hang new Primary Chain Case Cover Gasket on Dowels.
22. Install the Outer Primary Chain Case Cover over the Primary Chain Case Cover Gasket.
23. Start thirteen $\frac{1}{4}$ - 20 SHCS with $\frac{1}{4}$ flat washers into the Outer Primary Chain Case Cover.

24. Torque the Outer Primary cover bolts to 108–120 IN-LBS in the sequence below.

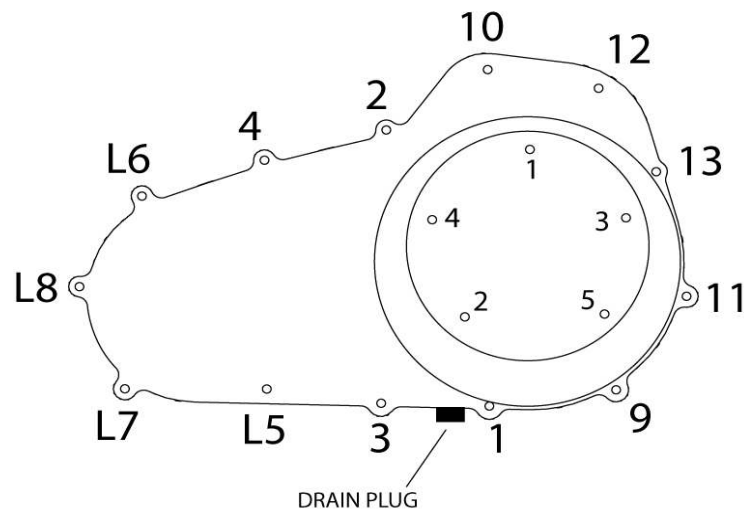

- 25. Apply thread sealant to the Drain Plug and reinstall.**
- 26. Remove five 1/4 - 20 torx head cap screws and the Clutch Inspection Cover.**
- 27. Fill the Primary Chain case with 45 oz of Primary Chain case Lubricant.**
- 28. Swab all lubricant from the Quad Ring groove in the Primary Chain Case Cover. Reinstall Quad Ring.**
- 29. Using the five 1/4 - 20 torx head cap screws replace the Clutch Inspection Cover. Torque to 84-108 IN-LBS in the sequence above.**
- 30. Reinstall the shift rod rubber.**
- 31. Reinstall the Inner and Outer Shift Levers.**
- 32. Reinstall the Front Drivers Footboard using the OEM fasteners.**

MODIFICATION OF FRAME:

1. Cut frame as shown below.

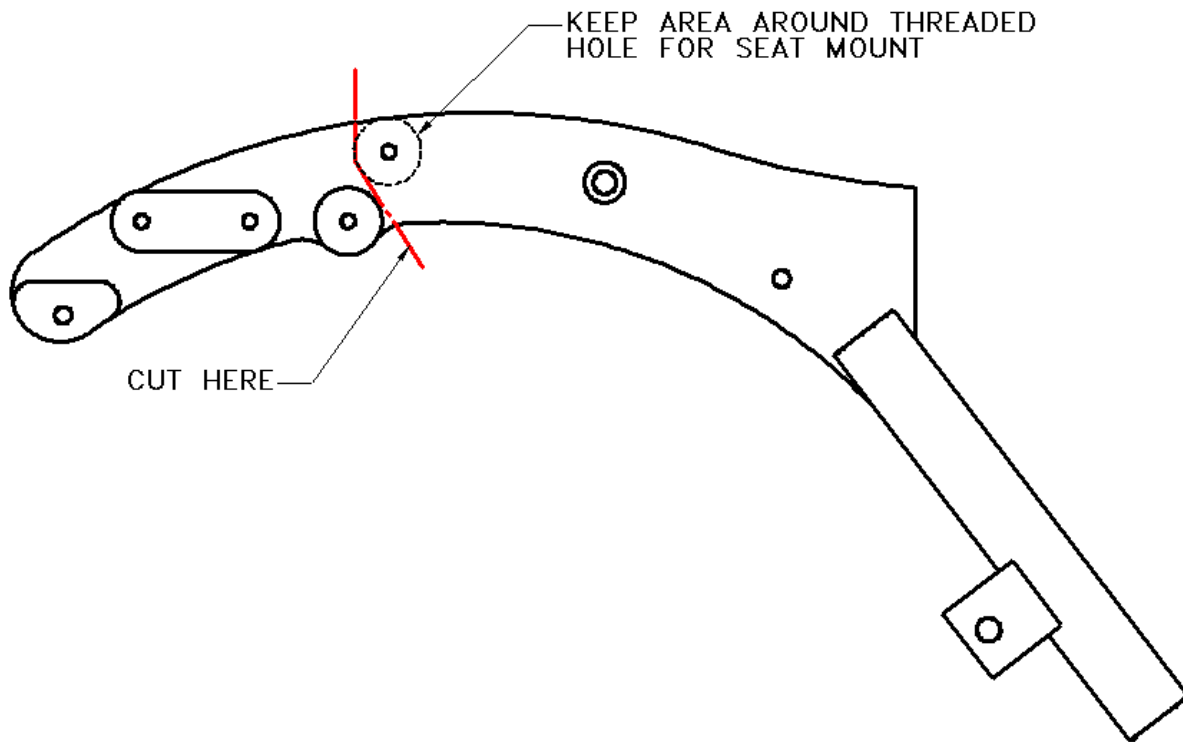

2. ENSURE BATTERY HAS BEEN REMOVED! Cut battery box in shaded areas as shown below.



Rear Suspension Unit Installation:

- 1. Install the Seat mount using two 5/16 - 18 x 1 HHCS with flat washers into the rear tapped frame bosses leave loss. Using two 5/16 - 18 x 1 1/2 HHCS with flat washers thru the front frame thru holes into the Seat mount, place a flat washer and nyloc nut and tighten to spec.**
- 2. Insert the Stud Plate into the holes of the Backrest Mount. Place the two Retaining Washers over the studs.**
- 3. Install two frame spacers on the inside of the upper shock mount location.**
- 4. Make sure that the Right Rubber Engine Mount is still in place.**
- 5. Place Suspension Unit behind prepared motorcycle as shown below. Using a small Jack under the Oil Pan and a Jack under the Suspension unit.**

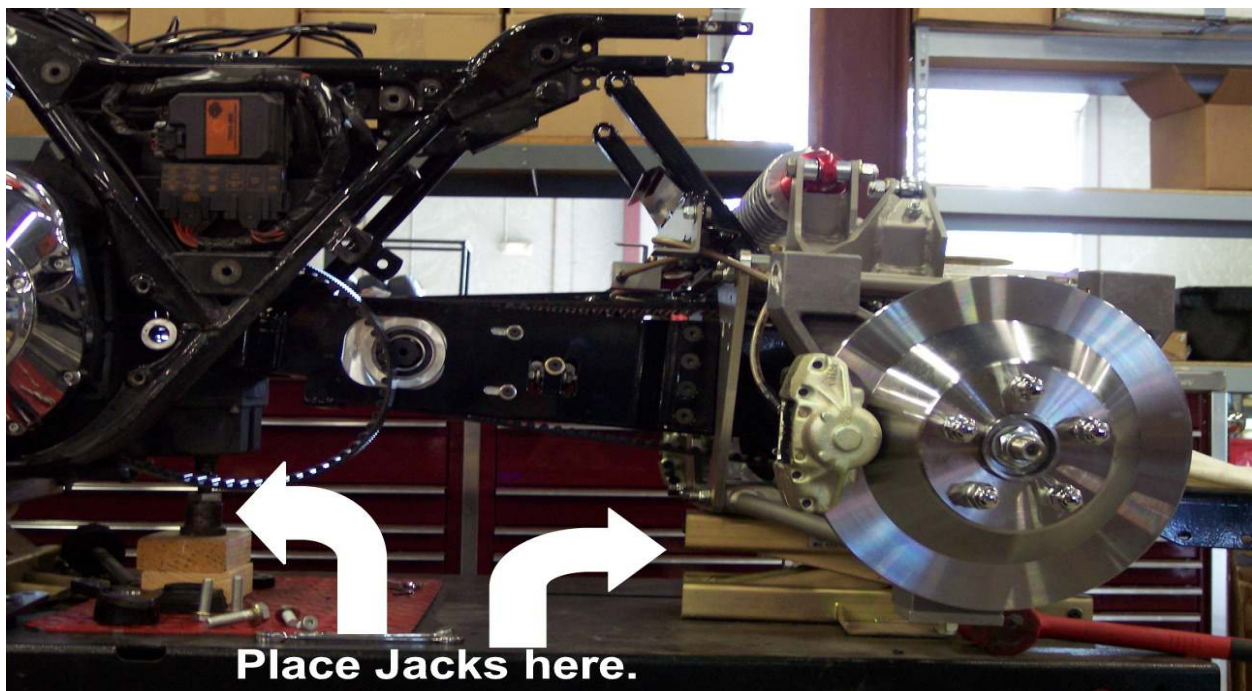

- 6. Slide Suspension unit as far forward as possible and install Drive belt onto Drive Sprocket.**

- 7. Using two 1/2 - 13 x 3 1/2 HHCS and two 1/2 flat washer with thread locking agent. Install the Intermediate Mount to the inside of the upper Air Shock mounting holes. Do not tighten.**
- 8. Raise the front Jack until the hole through the Transmission for the Rear Fork Pivot is in the center of the two holes for the Rear Fork Bracket.**
- 9. Apply a light coating of Anti Seize Compound to the Rear Fork pivot Shaft.**
- 10. Insert the shaft from the left. The Rear Fork Pivot Shaft will go thru the left side Drive Support Bushing, Transmission, right side Drive Support, right side Engine Mount, and thru the frame.**
- 11. Loosely install the Right Rear Fork Pivot shaft Nut and Cup Washer onto the Rear Fork Pivot Shaft. Apply thread locking agent.**
- 12. Install the Left Rear Fork Bracket using the OEM two 7/16 - 14 HHCS. Ensure the locating pin on the back side of the Left Rear Fork Bracket is in the mating slot of the Rubber Engine Mount.**
- 13. Torque the Rear Fork Pivot Shaft Nut to Specification.**
- 14. Remove two OEM 7/16 - 14 HHCS on the Left Rear Fork Bracket. Install the Frame Adapter with two 7/16 - 14 x 1 1/4 SHCS (apply thread locking agent). Torque to spec.**
- 15. Remove two plastic plugs in the threads then install Right Frame Adaptor by using 7/16 - 14 x 5/8 SHCS. (apply thread locking agent).**
- 16. Install the Left Frame Mount with one 1/2 - 13 x 1 1/2 SHCS thru the Frame Adaptor threading into the forward boss. Use thread locking agent.**
- 17. Insert two 5/16 - 18 x 1 3/4 SHCS into the upper and lower bosses of the Frame Mount then thru the tabs on the Suspension unit.**

- 18. Using two 5/16 flat washers and two 5/16 - 18 nyloc nuts tighten the three SHCS.**
- 19. Repeat for the Right Frame Mount.**
- 20. Torque all fasteners left loose to spec. (shock bolts, seat mount bolts,)**

Brake Line Installation:

- 1. IF A.B.S. Equipped refer to A.B.S. installation instructions now.**
- 2. Remove the two wire clips from the rear stop lamp switch.**
- 3. Remove the Banjo Bolt from the Rear Master Cylinder.**
- 4. Remove the Rear Brake Hose.**
- 5. Remove the Rear Stop Lamp Switch from the junction in the Rear Brake Hose.**
- 6. Re-clamp the Wire Harness Clips that were previously used to clamp the Rear Brake Hose.**
- 7. Reinstall the Rear Stop Lamp Switch into the new Rear Brake Hose. Use proper thread sealant on the Rear Stop Lamp Switch.**
- 8. Route new Rear Brake Hose with the bent banjo fitting towards the Rear Master Cylinder. The Rear Brake line will be on the outside of the Rear Master Cylinder. See Photo.**
- 9. Using the Short Banjo Bolt and two Crush Washers. Install the bent banjo fitting onto the Rear Master Cylinder. Torque to specification.**



- 10. Route the Rear Brake Hose along the Frame.**
- 11. Use Cable Ties to hold the Rear Brake Hose to the Frame.**
- 12. Install the two wiring connectors back onto the Rear Stop Lamp Switch.**
- 13. Route the Rear Brake Hose to the inside of the Frame and onto the Distribution Block.**
- 14. Using the Long Banjo Bolt and two Crush Washers. Install the straight banjo fitting onto the Distribution Block.**
- 15. Using Cable Ties secure the Rear Brake Hose to the Frame.**

Brake bleeding procedure:

NOTE: if ABS equipped refer to separate instructions.

1. Using correct brake fluid, fill Rear Brake Master Cylinder Reservoir.
2. Using a vacuum bleeder, follow this procedure **carefully**.
Standard Brakes
 - a. Bleed both rear upper bleed valves**Performance Brakes**
 - a. Rear caliper rear bleed valves outsides first then insides on each side.
 - b. Rear caliper front bleed valves outsides first then inside on each side.
3. Hand bleed the system using the above sequence. Until all air is removed from the lines.
4. Allow the bike to set for a minimum of 20 minutes and recheck the pedal travel.
5. If there is excessive pedal travel on the first pump, repeat steps 3 and 4.



Gravel Pan:

- 1. Install Gravel Pan with three 1/4-20 x 3/4 HHCS four flat washers and three nyloc nuts in the rear.**
- 2. Install the Gravel Pan Mount Plate into the recess area in the motorcycle frame.**
- 3. Using two 5/16-18 x 1 HHCS two flat and two lock washers thru the Gravel pan then the frame and thread into the Mount Plate and tighten all fasteners.**

Exhaust Mount Installation:

- 1. Place the Left Exhaust Mount against the left side of the Body Frame.**
- 2. Install three 5/16 - 18 x 1 1/4 HHCS and three 5/16 flat washers thru the Exhaust Mount and the Body Frame.**
- 3. Install Trailer Hitch now if equipped.**
- 4. Loosely install three 5/16 flat washers and three 5/16 - 18 nyloc nuts.**
- 5. Install the right side with the same procedure.**

Exhaust Installation:

- 1. Install the Rubber Mounts onto the Mufflers with two 1/8 thick washers in between the Rubber mount and the Muffler body if needed.**
- 2. Install Exhaust Mount – T onto the Rubber Mounts with four 3/8 flat washers and four 5/16 – 18 nyloc nuts.**
- 3. Place one stock Muffler Clamp onto each Rear Exhaust Pipe.**
- 4. Slide the Right Rear Exhaust Pipe onto the Right Exhaust Pipe. See photo.**

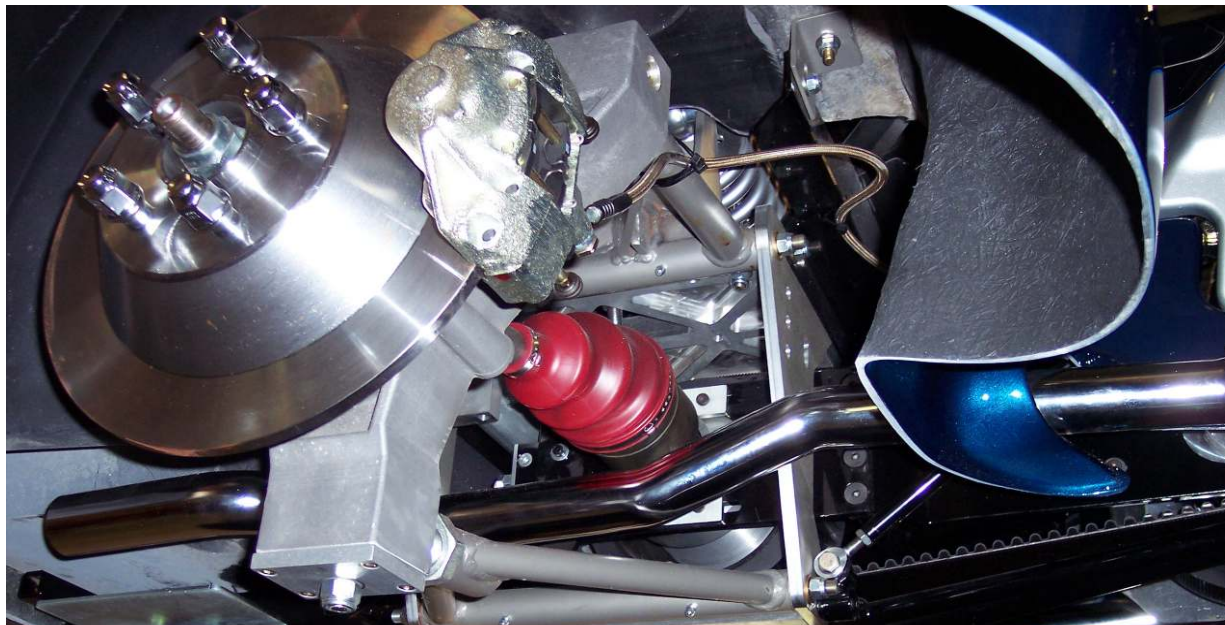

- 5. Slide the Left Rear Exhaust Pipe onto the Left Exhaust Pipe.**
- 6. Place two new Exhaust Clamps onto the Mufflers and slide the mufflers onto the Left and Right Exhaust Pipes.**
- 7. Install four 5/16 – 18 x 1 HHCS with 5/16 flat washers and four 5/16 – 18 nyloc nut into the slotted holes.**
- 8. Align the Mufflers into the Trike Body cutout and tighten all the Exhaust Clamps and hardware.**
Note: Insure there is a 1/2 inch air gap around the inner C.V. joint

Link to CSC Belt Tensioning video:

<http://www.californiasidecar.com/support.html>

Setting up the Sonic Tension Meter:

1. Turn power on, Push Select then 1.
2. Using the charts below in Front and Rear belt tensioning push Mass then the numbers, Width and so on.
3. For the Rear belt push Select then 2. Reverse belt can be number 3 and so on.

Using the Sonic Tension Meter:

1. The microphone placement over the belt is critical.
 - a. The microphone should be in the middle of the belt width-wise.
 - b. The microphone should be equally in-between the two Sprockets.
 - c. The microphone should be between $\frac{1}{4}$ and $\frac{1}{2}$ an inch above or below the Belt.
2. Turn the Sonic Tension Meter on.
3. Ensure that the correct setting is displayed on the LCD screen.
4. Push MEASURE then gently tap the Belt with a wrench while holding the microphone in the correct position. A measurement in Lbs. of single span tension should display. If not continue tightening the Belt until a reading is displayed.
5. In noisy environments the Sonic Tension Meter may display errant numbers. If so use in a quieter area.
6. Always take at least THREE readings of the Belt tension and average the THREE readings to determine the actual tension of the Belt.

Tensioning the Front Drive Belt:

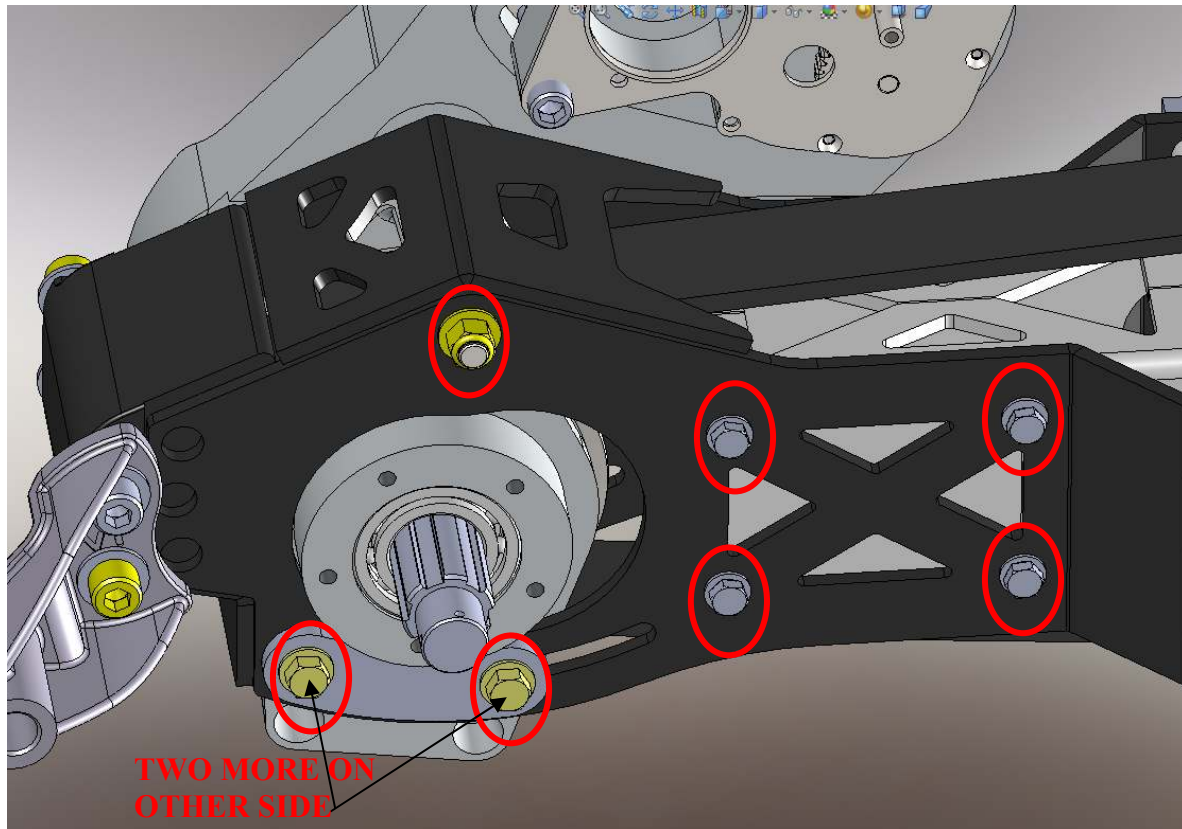

1. Loosen the four HHCS in the rear only on the left side. Next loosen the four clamping HHCS two per side and the one upper pivot shaft nyloc nut.
2. Tighten the Rear Drive Belt adjuster nuts until the slack is taken up on the Front Drive Belt.
3. Use the correct setting on the Sonic Tension Meter.
MASS 007.9 g/m
WIDTH 028.0 mm
SPAN 0341 mm
4. Check Front Drive Belt tension.
28MM Belt: 130 - 150 lbs. single span tension.
5. Once the correct belt tension is achieved tighten all fasteners previously loosened in step 1. Eight HHCS and one nyloc nut.
6. Verify belt tension.
7. If incorrect start back at step 1. If correct proceed to Rear Belt Tensioning.

Tensioning the Rear Drive Belt:

1. See diagram below.

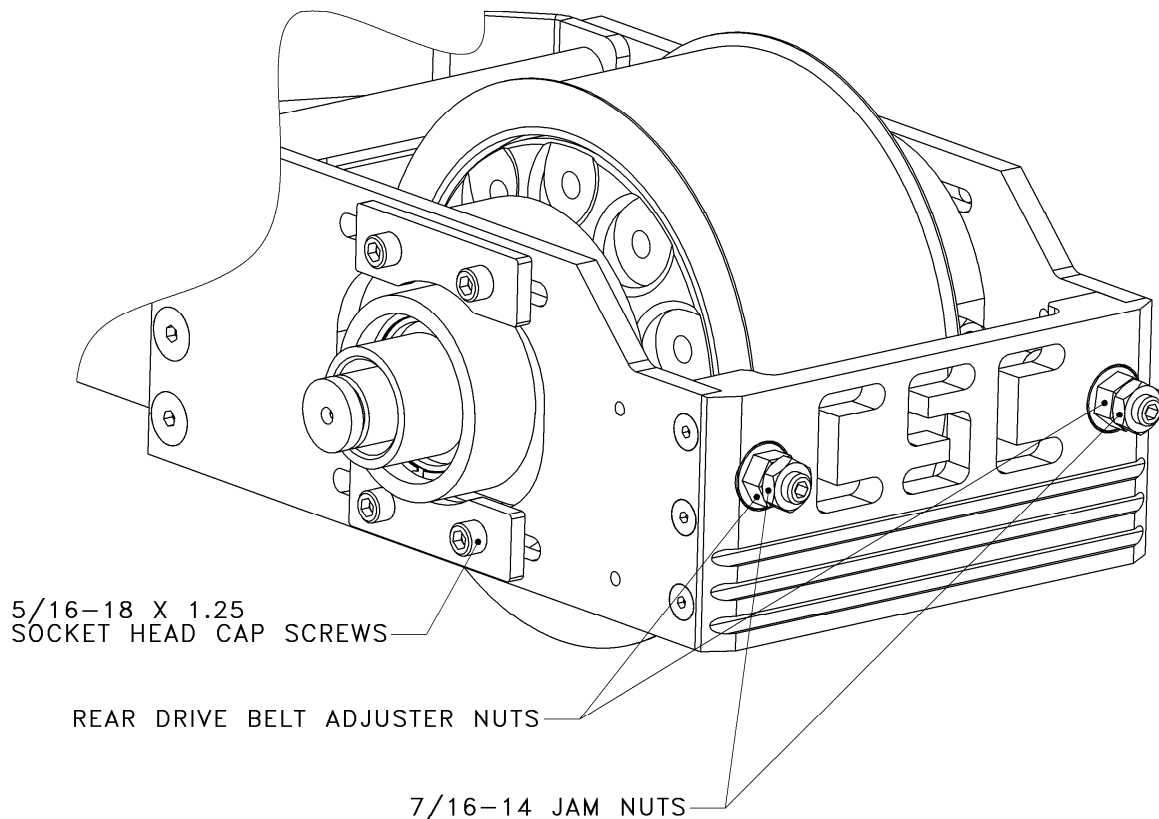

2. Tighten the Rear Drive Belt Adjuster nuts until the slack is taken up on the Rear Drive Belt.

3. Use the correct setting on the Sonic Tension Meter.

MASS 007.9 g/m
WIDTH 050.0 mm/R
SPAN 0442 mm

4. Check Rear Drive Belt tension.

5. 50mm belt: 130 - 150 lbs. of single span tension.

6. In the next step you are going to run the engine. Please be aware of the safety of all those involved. Make sure you have at least two lug nuts on each rotor and that they are tight.

7. To finish alignment, the belt must have at least 0.040in clearance between edge of belt and fence on front Rear

Drive Sprocket. Check this by starting the engine and placing it in second gear and simply let the engine idle. Checking the alignment by eye and centering the belt as it spins. If belt has correct clearance, go to **step 9. If it does not have clearance, proceed to **step 8**.**

- 8. Use the Left and Right Rear Drive Belt Adjuster Nuts to align belt in order to achieve the necessary belt clearance. NOTE: The belt will always track to the side of the sprocket that is the loosest. Repeat step 4.**
- 9. Once the correct belt alignment and single span tension is achieved, tighten the eight 5/16 – 18 x 1 ¼ SHCS that go into the Carrier Bearing Support Housings.**
- 10. Install two 7/16 – 14 hex jam nuts onto the Rear Drive Belt Tensioning Studs and tighten.**
- 11. Verify belt tension and alignment.**
- 12. If all is correct move on to next step. If not loosen clamping bolts and return to step 4.**

Service Limits on Drive Belts:

Service limit on the Front Drive Belt is 130 - 150 lbs.

Service limit on the Rear Drive Belt is 130 - 150 lbs.

Suspension Setup:

Use this chart to select the correct spring preload.

Rotate the adjuster nut on the shock until the spring is set to the desired length. Now tighten the set screw on the adjuster nut or tighten the lock nut on the fully adjustable shock.

Load: Typical weight the customer adds to the stock trike. This includes riders, luggage, and weight of a trailer tongue.

When in doubt assume a higher weight than actual.

Length: Suggested length the spring should be adjusted to with the suspension completely unloaded and the preloader adjusted all the way out.

DAYTONA (w/ TourPack)								
STANDARD SHOCK								
	LOAD	LENGTH		LOAD	LENGTH		LOAD	LENGTH
300 LB/IN SPRING	100	11 7/8	325 LB/IN SPRING	100	11 15/16	350 LB/IN SPRING	100	11 15/16
	200	11 11/16		200	11 3/4		200	11 3/4
	300	11 1/2		300	11 9/16		300	11 5/8
	400	11 5/16		400	11 3/8		400	11 1/2
	500	11 1/8		500	11 3/16		500	11 5/16
	600	10 7/8		600	11		600	11 1/8
	700	10 11/16		700	10 13/16		700	11
	800	10 1/2		800	10 5/8		800	10 7/8
ADJUSTABLE SHOCK								
	LOAD	LENGTH		LOAD	LENGTH		LOAD	LENGTH
300 LB/IN SPRING	100	11 3/8	325 LB/IN SPRING	100	11 7/16	350 LB/IN SPRING	100	11 1/2
	200	11 3/16		200	11 1/4		200	11 3/8
	300	11		300	11 1/8		300	11 1/4
	400	10 13/16		400	10 15/16		400	11
	500	10 5/8		500	10 3/4		500	10 15/16
	600	10 3/8		600	10 1/2		600	10 3/4
	700	10 3/16		700	10 5/16		700	10 9/16
	800	10		800	10 1/8		800	10 7/16

1. Install preload adjuster now if equipped. Refer to separate installation instructions.
2. Install Fully Adjustable shock adjuster now if equipped. Refer to separate installation instructions.

These lengths are only estimates. If you would like to confirm a correct setting, load the completed trike to the customers typical riding situation and measure from the ground to the middle of the lower suspension plate. The center hole should be 5.75" – 6.25" from the ground.

Attention: This is the only suspension adjustment needed. All other settings are factory set and should not be tampered with. There is no need to remove trike from the lift to check camber, toe, or the drop links.

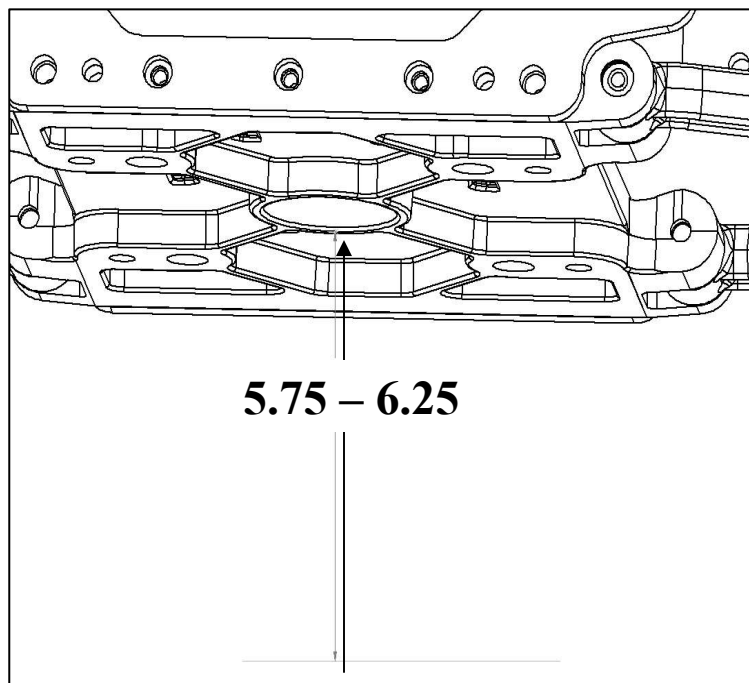

Body installation:

1. Lower the body onto the trike with the front of the body pointing downward until it comes to rest onto the upper tray and body frame as shown.



Tour Pak Installation:

1. Apply silicone sealant to both sides of the four rubber spacers and in the holes in the body.
2. Place the rubber spacers over the four holes predrilled in the body.
3. Lower Tour Pak down onto the rubber spacers.
4. Install four 1/4 - 20 HHCS with flat washers thru the Tour Pak then the rubber spacer and finally thru the predrilled holes in the body.
5. Install four fender washers and 1/4 - 20 nyloc nuts from the inside of the body.

- 6. Adjust Tour Pak into alignment and tighten bolts.**
- 7. Reconnect Tour Pak wiring.**
- 8. Route the Trunk Emergency Release cable along the right side of the Frame and tie just behind the Right Side Cover.**
- 9. If installing Ground Effects see attached instruction packet.**
- 10. Connect Body Wiring Harness connector under the Frame to the Rear Fender Wiring Harness Connector.**
- 11. Route the Fuse-able Link and the White Wire towards the Battery.**
- 12. Install the Right and Left Side Covers.**

Trike body alignment:

- 1. The Trike Body can move left, right, forward, backward, up, down, and angled. Shimming with the provided 1/4 and 1/8 Rubber Washers may be required to get the Trike Body into alignment.**
- 2. First raise the front of the body to obtain the vertical location around the Side Covers.**
- 3. Then slide the body front to back to get the horizontal location around the Side Covers.**
- 4. With the body temporarily held into place, raise the adjustable 90° body support brackets until they seat against the body's inner liner.**
- 5. Tighten the two 5/16 - 18 x 3/4 HHCS and two 5/16 - 18 nyloc nuts on the Adjustable 90° Support Brackets.**
- 6. Center the Trike Body left to right with the Trailer hitch (if equipped) and Side Covers.**

Securing the Trike body:

- 1. Using a 5/16 twist drill, drill up through the Adjustable 90° Body Support Brackets.**

Note: A small section of Trike Body Carpet has not been glued at the location of the Trike Body Frame mounting tabs to allow removal of the bolts used in shipping, and installation of the Trike Body mounting hardware. The predrilled bolt holes may need to be enlarged or relocated for Trike Body attachment to the Trike Body Frame mounting tabs. If relocation is necessary, the preexisting holes will need to be sealed with silicone sealant.

- 2. Using a 5/16 twist drill, drill up through the Trike Body Frame mounting tabs.**
- 3. Insert two 5/16 – 18 x 1 ¼ HHCS, two 5/16 x 1 ½ fender washers, and rubber washers if necessary through the holes drilled in step 2.**
- 4. Insert two 5/16 – 18 x 1 ¼ HHCS and two 5/16 x 1 ½ fender washers through the adjustable 90° body support brackets.**
- 5. Install four 5/16–18 nyloc nuts and four 5/16 flat washers onto the four 5/16–18 x 1 ¼ HHCS and tighten.**

Reassembly of the motorcycle:

- 1. Replace the 15 AMP “lights” fuse with the 20 AMP fuse provided.**
- 2. Connect the red wire with Fuse Holder to the Positive Battery terminal.**
- 3. Reconnect the negative battery terminal and the new white wire from the Tike Body Wiring Harness.**
- 4. Replace the Seat and $\frac{1}{4}$ - 20 Phillips head screw.**

Final Reassembly of the motorcycle:

- 1. Install the Wheel Spacers with the flat surface towards the Brake Rotor. Only to be installed with our 9-Spoke wheel.**
- 2. Reinstall the wheel and tire assemblies with ten m12 x 1.5 ET conical lug nuts. Torque to 65 ft/lbs.**

Refer to the Maintenance Schedule on p. 5 for details regarding future service inspections and maintenance.

**From all of us at California Sidecar.
Enjoy the ride.**