

COBRA & COBRA XL BY



Ground Effects Installation Instructions

Revised 1 - 2012

- 2 - Front mount clamp
- 2 - Lower front mount
- 2 - Middle mount (1 left / 1 right)
- 2 - Middle Mount Wing (1 left / 1 right)
- 1 - GFX hardware bag (FST – 87912)
- 1 - Middle Mount Cross Brace
- 1 - Wiring harness
- 4 - butt connector
- 1 - Mini Fuse, 10 amp
- 2 - Rubber strips

**ALL ORDERS ARE DOUBLE CHECKED
TO ELIMINATE SHIPPING ERRORS.**

FILLED BY: _____

CHECKED/PACKED BY: _____

FRONT MOUNT CLAMP

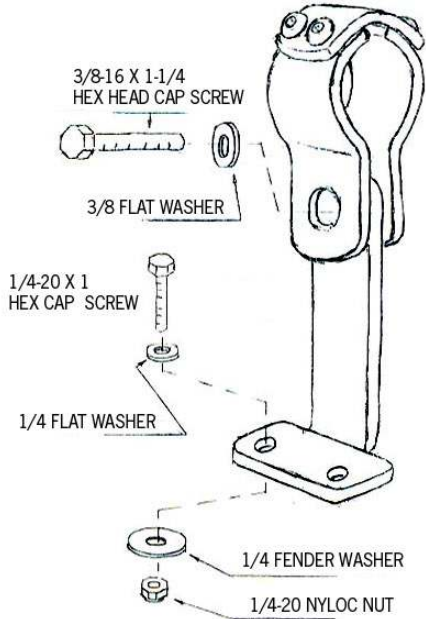

2006 COMFORT PACKAGE MODELS

M8 X 1.25 X 50
BUTTON HEAD
CAP SCREW

MIDDLE MOUNT

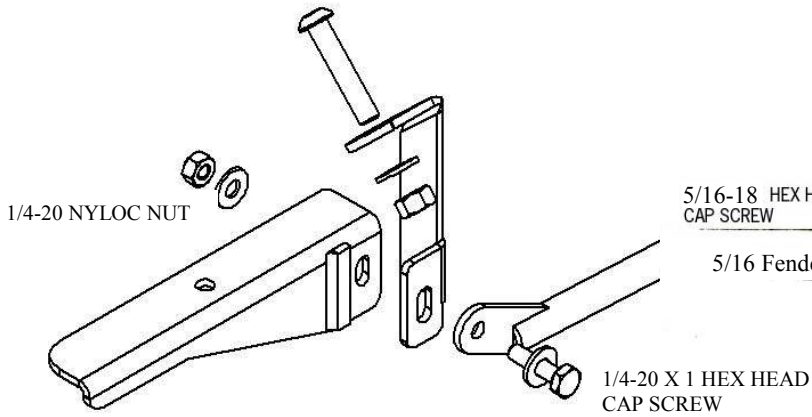

REAR MOUNT

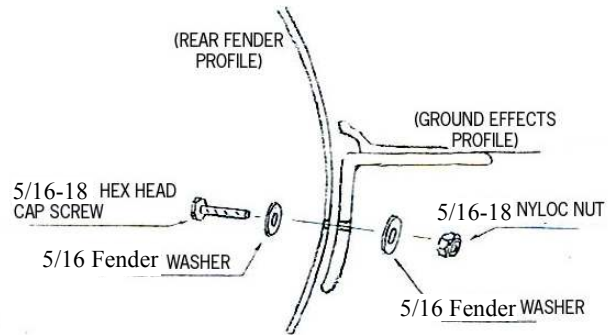

.For installation assistance, call Parts & Service @ 434.263.8866

IMPORTANT

The California Sidecar *Ground Effects* are designed to fit the California Sidecar Cobra Trike Conversion Kit only. They are NOT intended to support the standing weight of the rider or the passenger.

The *Ground Effects* are designed and intended to ONLY ACCOMMODATE THE STOCK HONDA RIDER FOOTPEGS.

Wiring Installation:

- 1. Remove the seat and passenger grip handles with the four M8 x 1.25 SHCS.**
- 2. Plug the four pin GRD EFX harness into the four pin connector at the body connectors (2 red and 2 blue connectors).**
- 3. Secure the GRD EFX box to the motorcycle frame or inner fender.**
- 4. Route the purple and black wires to the left side and the brown and black wires to the right side.**
- 5. Replace the seat and passenger grip handles with the four M8 x 1.25 SHCS.**

Ground Effects Installation:

- 1. Disconnect the three pin connector at the sidestand switch.**
- 2. On the sidestand side of the connector cut 2 inches from the connector.**
- 3. Strip the two green wires and connect them together with a butt connector.**

4. Tape or shrink tube all three wires.
5. Remove the side stand.
6. Front mounts – (left & right)

2006 & UP Comfort Package Models Only

Refer to picture above. Cut opening in rubber boot 1/2" wide and 1 3/8" long. Insert the two clamp halves through opening in rubber boot with weld nut facing forward. It is not necessary to install top of clamp or the 4 button head cap screws.

- a. Install clamp on rear tube of engine guard, with weld nut facing forward.
- b. Tighten four 6mm button head cap screws.
- c. Compress clamp flats with pliers allowing enough gap to insert lower front mount with foot facing rear.
- d. Align holes and install 3/8-16 x 1 1/4 hex head cap screw. Do not tighten.

7. Middle mounts – (left & right)

- a. Remove front foot rest clevis pin & replace with M8x1.25 x 50 button head cap screw.
- b. Attach middle mount bracket to bolt at bottom/rear of foot rests on right and left sides, and secure using washer and nyloc nut.

IMPORTANT: On right side, align nut so it does not touch brake pedal. Bracket will slide between foot brake pedal and body skin. Also make note of brake pedal operation. Be sure bracket doesn't interfere with pedal movement.

- c. Install middle mount wings (left & right), with tabs facing front, and Cross Brace to brackets with $\frac{1}{4}$ -20 x 1" hex head cap screws, installing bolt from rear. Use two $\frac{1}{4}$ " washers (see diagram p. 2) with $\frac{1}{4}$ -20 nyloc nut, but do not tighten yet.

Note: Complete steps 7 – 13 for right and left sides.

8. Lay **Ground Effects** into place on middle mount wings, aligning to fender ensuring that the rear mating edge is level and the fiberglass bracket is contoured to the fender. Clamp bracket to fender (Vise-Grip®6-sp works well).

Note: In order to achieve optimum fit, you may find it necessary to grind slightly where the **Ground Effects** meet the fender.

9. Adjust front of **Ground Effects** so there is $\frac{1}{4}$ " or less gap between **Ground Effects** edge and lower cowl.
10. Holding this position, mark location of two lower front mount holes to the **Ground Effects**.
11. Remove clamp at rear and remove **Ground Effects**.
12. Drill two $\frac{1}{4}$ " holes at marked location.
13. Remove lower front mount from clamp and attach to **Ground Effects** (foot to rear) with two $\frac{1}{4}$ -20 x 1 hex head cap screws with $\frac{1}{4}$ washers. Use $\frac{1}{4}$ x 1 $\frac{1}{4}$ fender washers and $\frac{1}{4}$ -20 nyloc nuts on the underside.
14. Using super glue affix rubber strips to rear of the **Ground Effect** where they meet the fender.
15. Place **Ground Effect** in position and clamp rear to fender as in step 3.

16. Insert lower front mount between flats of clamp and install 3/8-16 x 1 1/4 hex head cap screw and 3/8 washer. Adjust **Ground Effect** location as in step 4, and tighten.

17. Rear mounts

- a. With clamp still in place, drill two 5/16" holes 3" up from bottom edge of fender ensuring holes go through fiberglass bracket approximately 1" from each side of bracket.
- b. Install two 5/16-18 x 1 hex head cap screws, pointing forward, with the bolt head on the inside of the trike body fender well. **DO NOT INSTALL the bolt with the threads inside the fender well.** Secure with 5/16 fender washers and 5/16-18 nyloc nuts. Do not over tighten. Remove clamp.

18. Middle mount wings

- a. If required, lift left wing so it contacts underside of **Ground Effect** and tighten 1/4 -20 x 1" hex head cap screws.
- b. Fold back unglued portion rubber mat, and drill 1/4" hole through **Ground Effect** from underneath using the hole in wing mount.
- c. Insert 1/4-20 flat head elevator bolt from top and secure with 1/4 washer and 1/4-20 nyloc nut. Do not over tighten.
- d. Secure rubber mat with contact cement or upholstery adhesive.
- e. Repeat steps a thru d for right side.

- 19. Ensure free movement of foot brake lever and gear shift lever.**
- 20. Drill a 3/16” hole on each side of the trike body, above the mufflers but underneath the *Ground Effect*, to run the wiring harness with relays through.**
- 21. Connect the left *Ground Effect* wiring harness to the installed wiring harness. The black wire to the black wire, and the purple wire to the purple wire with butt connectors.**
- 22. Connect the right *Ground Effect* wiring harness to the installed wiring harness. The black wire to the black wire, and the brown wire to the brown wire with butt connectors.**
- 23. Test the cornering lights to ensure that the lights operate with the appropriate turn signal, and the light remains illuminated until the turn signal is cancelled.**

**FROM ALL OF US AT CALIFORNIA SIDECAR.
ENJOY THE RIDE.**