



TRIKE CONVERSION KIT

KAWASAKI 1700

VULCAN VOYAGER

VULCAN VAQUERO

VULCAN NOMAD

INSTALLATION

INSTRUCTIONS

REVISED 1 - 2012

CALIFORNIA SIDECAR PARTS & TECHNICAL SUPPORT
434.263.8866

Table of Contents:

1. Warnings and Considerations	3
2. General Information	3
3. Maintenance Schedule	4
4. Disassembly of Motorcycle	5
5. Reassembly of Motorcycle	7
6. Rear Suspension Unit Installation	8
7. Brake Line Installation	8
8. Bleeding the Brake System	9
9. Gravel Pan Installation	9
10. Exhaust Mount Installation	10
11. Exhaust Tailpipe and Muffler Installation	11
12. Coolant Bottle Relocation	12
13. ABS Sensor	13
14. Link to CSC Belt Tensioning video	14
15. Setting up the Sonic Tension Meter	14
16. Using the Sonic Tension Meter	14
17. Tensioning the Front Drive Belt	15
18. Tensioning the Rear Drive Belt	16
19. Suspension Setup	18
20. Trike Body Installation	20
21. Trike Body Alignment	21
22. Securing the Trike Body	21
23. Tour Pak Installation	23
24. Reassembly of the Motorcycle	25
25. Final Reassembly of the Motorcycle	25

Warnings and considerations:

- 1. Disclaimer** - These instructions assume a level of understanding of motorcycle repair and maintenance beyond that of a “beginner” and/or “novice” and California Sidecar cannot be liable for an installer’s failure to understand or follow these instructions as written. Likewise, California Sidecar cannot be responsible if any of the steps are omitted or shortcuts are taken, or parts other than those supplied by California Sidecar, are used in installing this trike kit.
- 2. “WARNINGS”** are all printed in bold type and capitalized. They mean to use extreme care in a given step so as not to damage the part, motorcycle, and/or yourself.
- 3. Always wear safety glasses** when using hand and/or power tools.
- 4. When working in and around the fuel system, always work in a well-ventilated area, free from sparks and open flames.**
- 5. All directional references to the “right side” and the “left side” are as you were seated on the motorcycle.**
- 6. All directional references to “forward” mean to the front of the motorcycle while “back” means the rear of the motorcycle unless otherwise stated.**

Recommended Lubricants:

- 1. Fluorinated grease for splines**
- 2. Thread locking compound (Loctite 242 minimum).**
- 3. High temperature Silicone sealant.**

Torque values of fasteners:

- 1. 3/8–16 x 1 3/4 SHCS. 47 ft-lbs Frame mount**
- 2. M10 x 1.25 x 40 SHCS. 54 ft-lbs Frame mount**
- 3. Pivot shaft 90 ft-lbs**

Maintenance Schedule: KRUZE

Frequency (miles)	Daily	4k	8k	12k	16k	20k	24k
Item							
Belts	I	I	I	I	I	T	I
Brake Pads and Rotors [1]		I	I	I	I	I	I
Half Shaft Boots		L	L	L	L	L	L
Wheel Bearings [2]		I	I	I	I	I	I
Wheels and Tires		I	I	I	I	I	I
All Lighting	I						
Tire Pressure [3]	I						
Brake fluid		I	I	R	I	I	R

I: Inspect: clean, lubricate, and/or replace as necessary.

R: Replace

L: Lubricate

T: Tension

NOTE:

[1] Minimum pad thickness is 0.04 inches (1.02mm)

[2] Wheel bearing torque 200 FT.-LBS.

[3] Rear tire pressure 28 PSI

At higher odometer readings, repeat at frequency intervals established here.

Note:

This Schedule is in addition to the Kawasaki Maintenance Schedule

NOTICE:

The remote door opener installed on this unit has a very small electrical draw on your motorcycle battery. If your trike will be unriden for more than 2 weeks you should remove the 15 amp fuse from the red fuse holder located under your seat or right side cover. Another option is using a battery tender.

Service & Maintenance questions – contact Parts & Service at 434.263.8866

Disassembly of motorcycle:

1. Place the motorcycle on the lift and secure.
2. Remove driver and passenger seat.
3. Remove both saddlebags, 3 HHCS each.
4. Remove upper side covers, 1 phillips each.
5. Remove lower side covers, 1 phillips and 1 HHCS.
6. Remove the cable from the seat latch.
7. Remove side stand and side stand switch. Cut the black and green wires, strip them and connect with a butt connector.

VOYAGER MODELS:

8. Remove tour pak liner.
9. Remove the 4 inside phillips screws from rear LED taillight. Unplug wire harness and remove antenna cover and cord.
10. Remove tour pak, 4 HHCS.
11. Remove left chrome tour pak cover 7 phillips.
12. Remove right side chrome tour pak cover and taillight together 5 phillips
13. Remove the chrome frame covers, 4 BHSCS and 1 phillips each.
14. Remove the tour pak frame, 4 HHCS.

NOMAD MODELS:

15. Remove the rear frame covers, 4 SHCS each side.
16. Remove the backrest, 2 HHCS each.

BOTH MODELS:

17. Remove rear tire bar, 2 HHCS.
18. Remove left lower and rear right side heat shields by loosening the heat shield clamps.
19. Remove the rear cylinder heat shield, 2 hose clamps (just loosen clamps).
20. Remove 2 HHCS from mufflers
21. Remove saddlebag frame, 5 HHCS each.

22. Remove rear fender, 4 SHCS 2 HHCS and unplug fender harness. Saving the passenger seat hook.
23. Remove passenger floorboards, 2 HHCS each.
24. Remove the rear caliper, 2 HHCS and the brake line from the swingarm, 1 HHCS and 1 phillips.
25. Remove the ABS Sensor and save SHCS for reinstallation if equipped. Leave sensor plugged in.
26. Remove rear shocks. Save upper mount flat washers.
27. Remove pivot shaft and nut and save for reinstallation.
28. Remove swingarm and wheel assembly.
29. Cut rear of frame as shown by the red line.

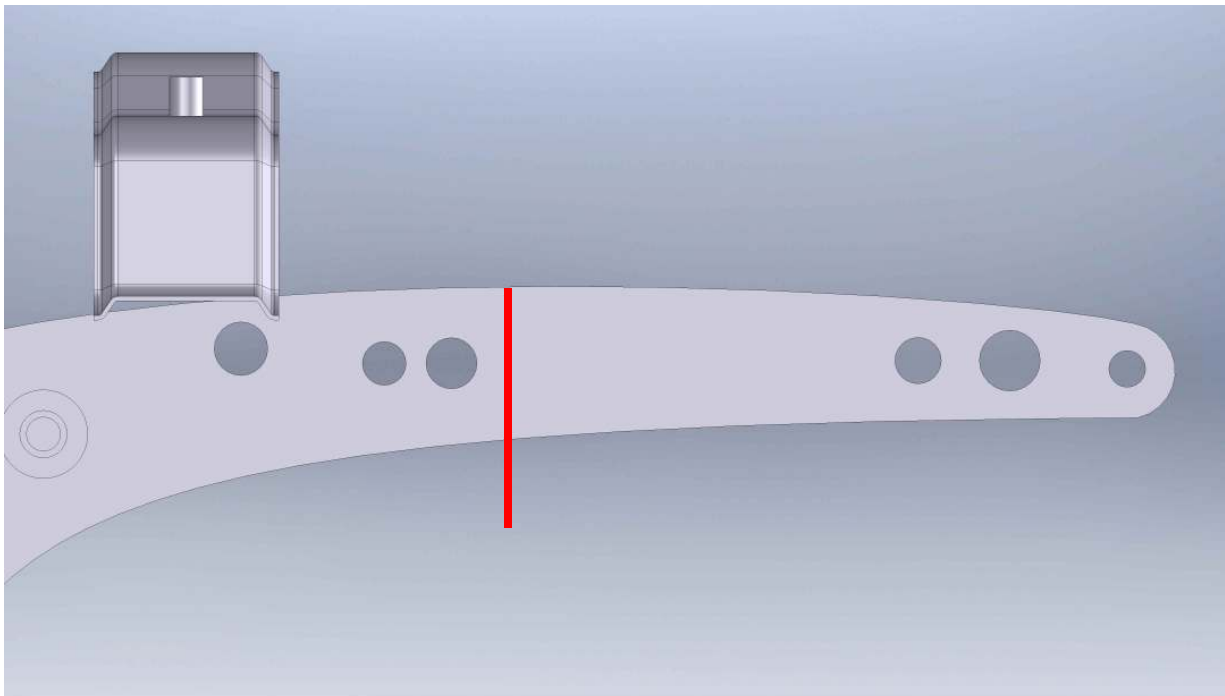

Step 30. Voyager and Nomad only.

30. Cut off right front middle side cover tab from frame.
31. Cut off rear fender stud located behind battery area.
32. From the front face of the large diameter of the muffler measure back and mark at 4 inches.
Both left and right.
33. Cut both mufflers at mark and discard rear of muffler.
34. Remove mufflers but leave clamps.
35. Rotate left muffler clamp so the bolt head is up.

36. Remove chrome sprocket cover, 3 SHCS.
37. Pull clutch lever in then zip tie around the lever and grip for the next step or you will loose clutch fluid)
38. Remove the clutch slave cylinder, 3 SHCS.
39. Remove sprocket cover, 4 SHCS.
40. Remove and discard the plastic belt guide inside the cover.
41. Straighten the tab on the sprocket and remove the nut and sprocket.
42. Remove the belt.

Reassembly of the motorcycle:

1. Install new CSC drive belt.
2. Reinstall the sprocket and nut. Torque the nut to 129 FT.-LBS.
3. Bend tab on the nut.
4. Reinstall the sprocket cover, slave cylinder, and chrome cover.

**Install ELECTRIC REVERSE wire harness now if equipped.
Refer to separate installation instructions.**

Rear Suspension Unit Installation:

- 1. Place the rear suspension unit onto a floor jack.**
- 2. Slide unit into place as far forward as possible.**
- 3. Install drive belt onto sprocket.**
- 4. Align pivot shaft holes. Apply a light coat of grease on pivot shaft and install from left to right. Install nut but leave loose.**
- 5. Slide the left frame brace over the shock shaft and install OEM washer and new 10mm nyloc nut, leave loose.**
- 6. Install two 3/8 - 16 SHCS into the upper and lower tabs of the suspension unit. It may be necessary to raise or lower the kit to align the fasteners.**
- 7. Repeat for the right side.**
- 8. Install four 3/8 flat washers and four 3/8 nyloc nuts.**
- 9. Tighten all fasteners.**
- 10. Tighten the pivot shaft nut. Torque to specification. Reinstall the plastic pivot shaft cover.**
- 11. Now that the Rear Suspension is mounted. Finish the Reverse wiring installation. Refer to separate installation instructions.**

Brake Line Installation:

- 1. Route the OEM rear brake line to the inside of the frame and to the distribution block.**
- 2. Using the provided banjo bolt and new crush washers, install the banjo fitting onto the distribution block.**
- 3. Using cable ties, secure the rear brake line to the frame.**

Brake bleeding procedure:

A.B.S. Model: we recommend only hand bleeding.

- 1. Fill Rear Brake Master Cylinder Reservoir.**
- 2. Using a vacuum bleeder, follow this procedure carefully.**
 - a. Rear caliper rear bleed valves outsides first then insides on each side.**
 - b. Rear caliper front bleed valves outsides first then inside on each side.**
- 3. Hand bleed the system using the above sequence. Until all air is removed from the lines.**
- 4. Allow the bike to set for a minimum of 20 minutes and recheck the pedal travel.**
- 5. If there is excessive pedal travel on the first pump, repeat steps 3 and 4.**



Gravel Pan Installation:

- 1. All HHCS installed on the gravel pan should have the washers on the bolt heads and be installed from the bottom up through the gravel pan.**
- 2. Install the gravel pan under the tab on the lower rear mount with three 1/4 - 20 x 3/4 HHCS three flat washers and three nyloc nuts.**

3. Raise the front of the Gravel Pan and secure with two M6-1.0 x 12 HHCS.
4. Align and tighten all fasteners.

Exhaust Mount Installation:

1. Place the Left Exhaust Mount against the left side of the Body Frame.
2. Using the lower holes. Install three 5/16 - 18 x 1 1/4 HHCS and three 5/16 flat washers thru the Exhaust Mount and the Body Frame from the outside in.
3. Install Trailer Hitch now if equipped.
4. Loosely install three 5/16 flat washers and three 5/16 - 18 nyloc nuts.
5. Install the right side with the same procedure.
6. Tighten the six fasteners.

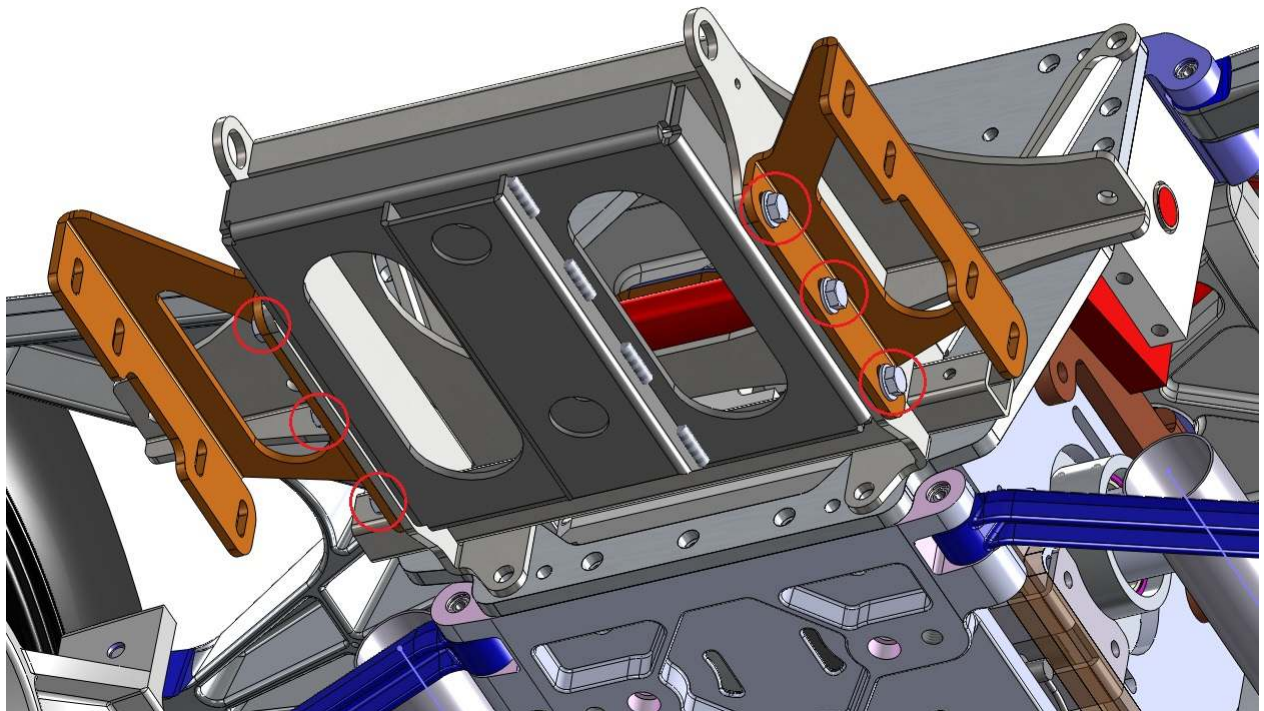

Exhaust Tailpipe and Muffler Installation:

- 1. First rotate the left exhaust clamp so the bolt can be tightened from the top.**
- 2. Reinstall the modified OEM right and left mufflers.**
- 3. Slide the Rear Tailpipes onto the modified mufflers using a 4 inch band clamp.**
- 4. Place one new Exhaust Clamp onto each of the Tailpipes for the mid mount and one on each muffler and slide the mufflers onto each Tailpipe.**

Note: Insure there is a $1/2$ inch air gap around the inner C.V. joint

- 5. Loosely install four $5/16 - 18 \times 3/4$ HHCS with $5/16$ flat washers into the mufflers. The mufflers should be in the forward most mounting holes.**
- 6. Tighten all clamps but leave the muffler bolts loose for vertical alignment later.**

Coolant Bottle relocation:

1. Remove the right side fastener from the seat latch.
2. Thread a new M6-1.0 x 40mm FHCS into the seat latch and tighten.
3. Install the small bracket as shown, from underneath onto the FHCS and secure with a nyloc nut.
4. Install the long bracket as shown, with a M6-1.0 x 12 HHCS and thread it into the frame from the inside out.
5. Remove coolant bottle from the frame.
6. Disconnect the hose from the bottom and move bottle to its new location.
7. Reconnect hose and mount bottle to the front of the brackets with two 1/4-20 x 3/4 HHCS, nyloc nuts and flat washers.

Picture shown is a rear view.

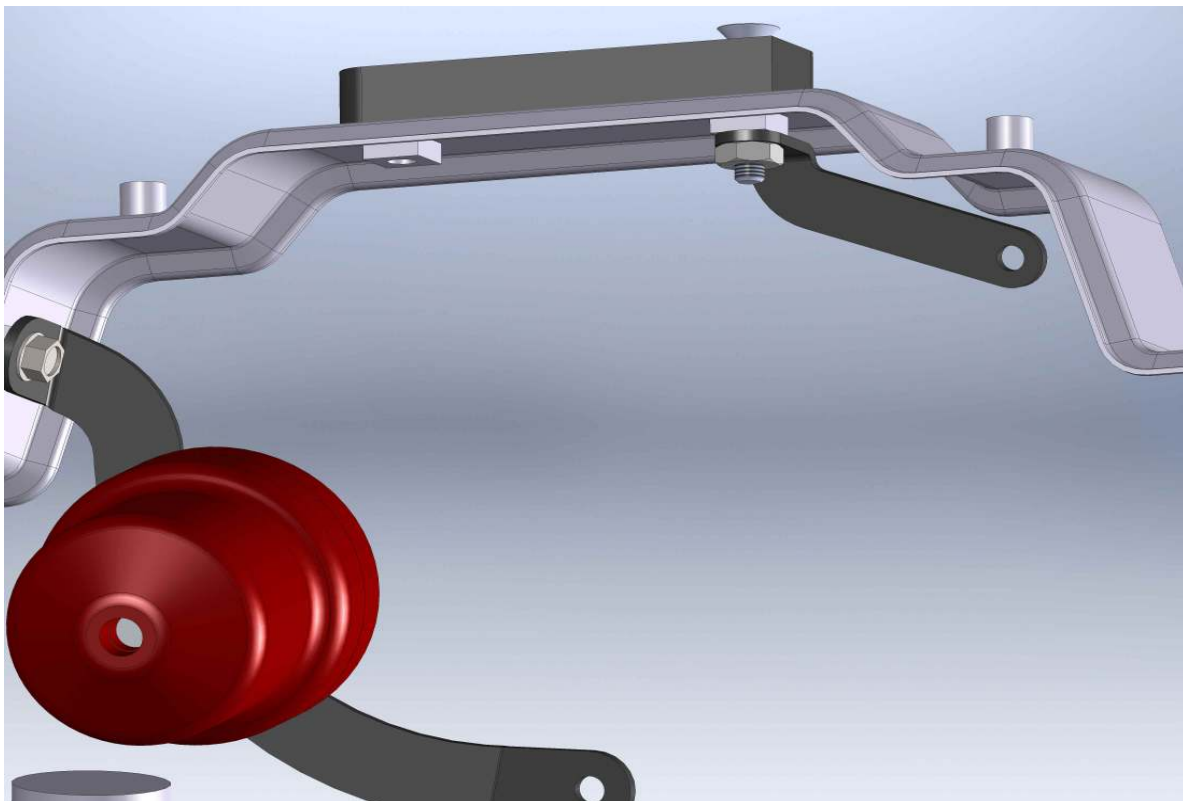

ABS Sensor Installation:

1. Reusing OEM SHCS install the ABS Sensor onto the rear sprocket clamping washer as shown.

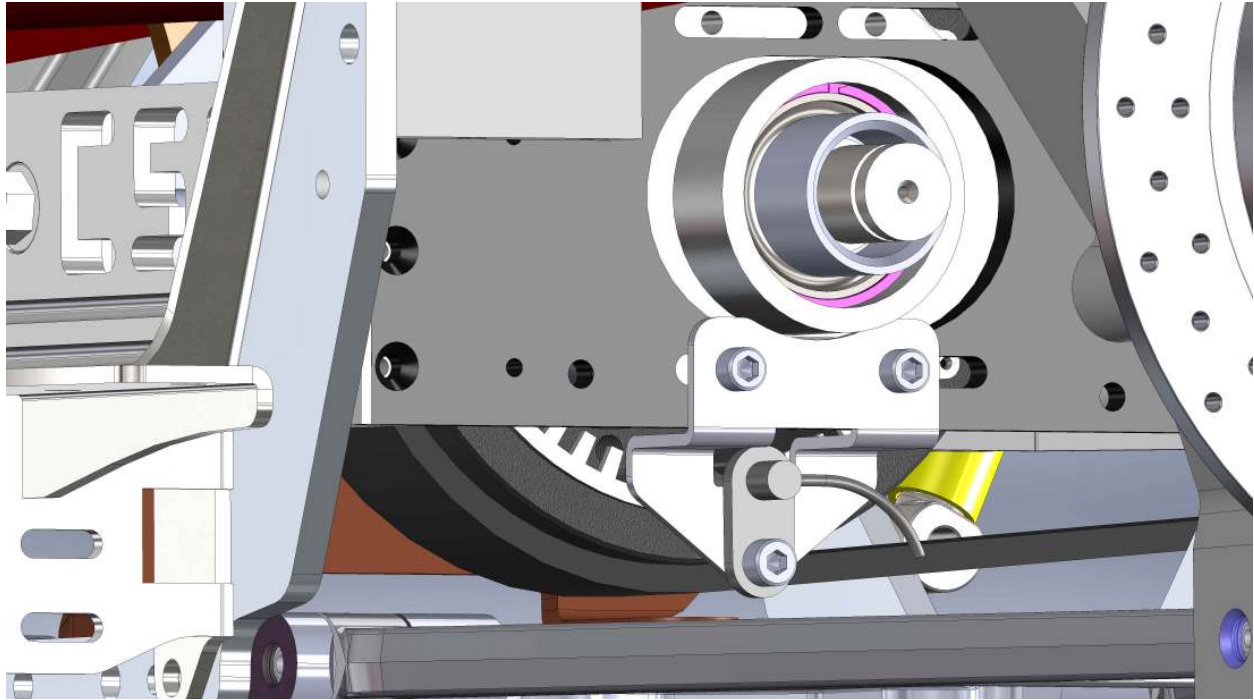

Link to CSC Belt Tensioning video:

<http://www.californiasidecar.com/support.html>

Setting up the Sonic Tension Meter:

1. Turn power on, Push Select then 1.
2. Using the charts below in Front and Rear belt tensioning push Mass then the numbers, Width and so on.
3. For the Rear belt push Select then 2. Reverse belt can be number 3 and so on.

Using the Sonic Tension Meter:

1. Using the Sonic Tension Meter.
2. The microphone placement over the belt is critical.
 - a. The microphone should be in the middle of the belt width-wise.
 - b. The microphone should be equally in-between the two Sprockets.
 - c. The microphone should be between $\frac{1}{4}$ and $\frac{1}{2}$ an inch above or below the Belt.
3. Ensure that the correct setting is displayed on the LCD screen.
4. Push MEASURE then gently tap the Belt with a wrench while holding the microphone in the correct position. A measurement in Lbs. of single span tension should display. If not continue tightening the Belt until a reading is displayed.
5. In noisy environments the Sonic Tension Meter may display errant numbers. If so use in a quieter area.
6. Always take at least THREE readings of the Belt tension and average the THREE readings to determine the actual tension of the Belt.

Tensioning the Front Drive Belt:

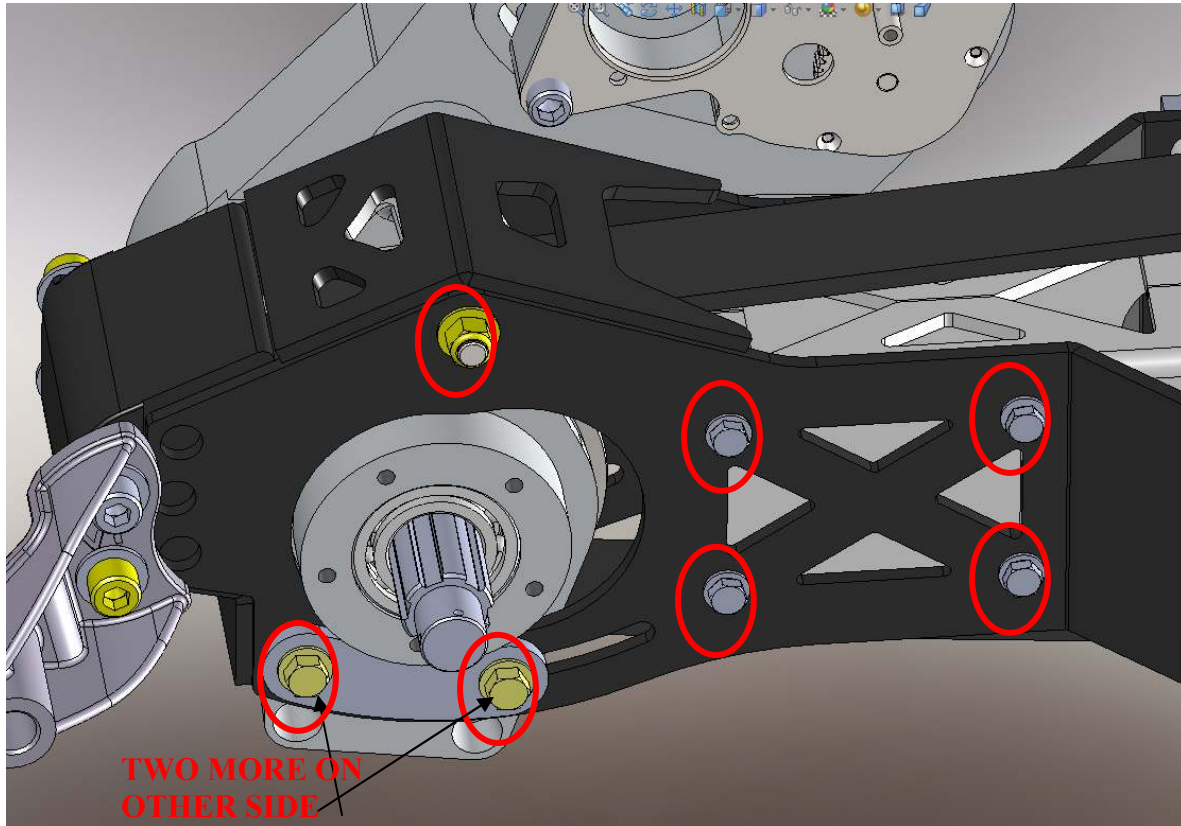

1. Loosen the four HHCS in the rear only on the left side. Next loosen the four clamping HHCS two per side and the one upper pivot shaft nyloc nut.
2. Tighten the Rear Drive Belt adjuster nuts until the slack is taken up on the Front Drive Belt.
3. Use the correct setting on the Sonic Tension Meter.
MASS 007.9g/m
WIDTH 028.0 mm/R
SPAN 0331 mm
4. Check Front Drive Belt tension.
28mm Belt: 120 – 140 lbs. of single span tension.
5. Once the correct belt tension is achieved tighten all fasteners previously loosened in step 1. Eight HHCS and one nyloc nut.
6. Verify belt tension. **NOTE:** Belt tension may increase once all bolts are tightened.

Tensioning the Rear Drive Belt:

1. See diagram below.

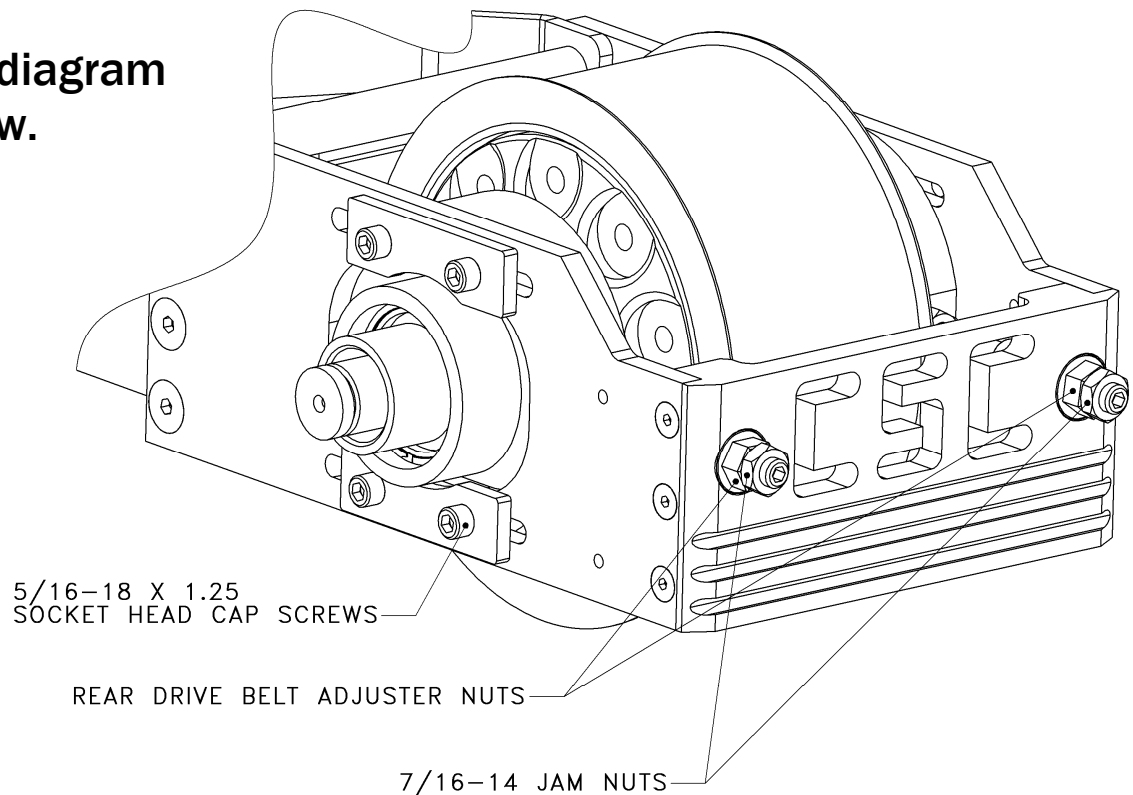

2. Tighten the Rear Drive Belt Adjuster nuts until the slack is taken up on the Rear Drive Belt.
3. Use the correct setting on the Sonic Tension Meter.
MASS 007.9 g/m
WIDTH 050.0 mm/R
SPAN 0442 mm
4. Check Rear Drive Belt tension.
50mm belt: 120 - 160 lbs. of single span tension.
5. In the next step you are going to run the engine. Please be aware of the safety of all those involved. Make sure you have at least two lug nuts on each rotor and that they are tight.
6. To finish alignment, the belt must have visual clearance between edge of belt and fence on front Rear Drive Sprocket. Check this by starting the engine and placing it in second gear and simply let the engine idle. Checking the alignment by eye and centering the belt as it spins. If

belt has correct clearance, go to step 8. If it does not have clearance, proceed to step 7.

7. Use the Left and Right Rear Drive Belt Adjuster Nuts to align belt in order to achieve the necessary belt clearance. NOTE: The belt will always track to the side of the sprocket that is the loosest. Repeat step 4.
8. Once the correct belt alignment and single span tension is achieved, tighten the eight 5/16 - 18 x 1 1/4 SHCS that go into the Carrier Bearing Support Housings.
9. Install two 7/16 - 14 hex jam nuts onto the Rear Drive Belt Tensioning Studs and tighten.
10. Verify belt tension and alignment.
11. If the tension is correct move on to next step. If not loosen clamping bolts and return to step 4.

Suspension Setup:

Use this chart to select the correct spring preload. Rotate the adjuster nut on the shock until the spring is set to the desired length. Now tighten the set screw on the adjuster nut or tighten the lock nut on the fully adjustable shock.

Load: Typical weight the customer adds to the stock trike. This includes riders, luggage, and weight of a trailer tongue. When in doubt assume a higher weight than actual.

Length: Suggested length the spring should be adjusted to with the suspension completely unloaded and the preloader adjusted all the way out.

KRUZE								
STANDARD SHOCK								
	LOAD	LENGTH		LOAD	LENGTH		LOAD	LENGTH
300 LB/IN SPRING	100	11 7/8	325 LB/IN SPRING	100	11 15/16	350 LB/IN SPRING	100	11 15/16
	200	11 11/16		200	11 3/4		200	11 3/4
	300	11 1/2		300	11 9/16		300	11 5/8
	400	11 5/16		400	11 3/8		400	11 1/2
	500	11 1/8		500	11 3/16		500	11 5/16
	600	10 7/8		600	11		600	11 1/8
	700	10 11/16		700	10 13/16		700	11
	800	10 1/2		800	10 5/8		800	10 7/8
ADJUSTABLE SHOCK								
	LOAD	LENGTH		LOAD	LENGTH		LOAD	LENGTH
300 LB/IN SPRING	100	11 3/8	325 LB/IN SPRING	100	11 7/16	350 LB/IN SPRING	100	11 1/2
	200	11 3/16		200	11 1/4		200	11 3/8
	300	11		300	11 1/8		300	11 1/4
	400	10 13/16		400	10 15/16		400	11
	500	10 5/8		500	10 3/4		500	10 15/16
	600	10 3/8		600	10 1/2		600	10 3/4
	700	10 3/16		700	10 5/16		700	10 9/16
	800	10		800	10 1/8		800	10 7/16

1. Install preload adjuster now if equipped. Refer to picture on page 11. Install two 10-32 x 1 BHSCS into the reservoir, mounted to the coolant bottle relocation brackets.
2. Install Fully Adjustable shock adjuster now if equipped. Refer to separate installation instructions.

These lengths are only estimates. If you would like to confirm a correct setting, load the completed trike to the customer's typical riding situation and measure from the ground to the middle of the lower suspension plate. The center hole should be 5.75" – 6.25" from the ground.

Attention: This is the only suspension adjustment needed. All other settings are factory set and should not be tampered with. There is no need to remove trike from the lift to check camber, toe, or the drop links.

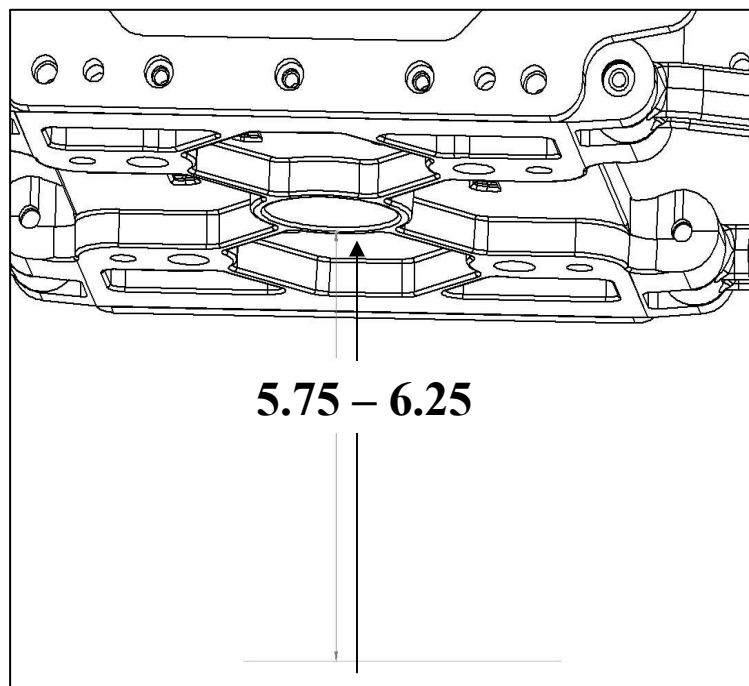

Trike Body installation:

1. If installing Electric Reverse or Ground Effects.
Install the controllers to the upper frame mount with two sided tape and zip ties using slots provided.
Connect and route the wiring. Refer to separate installation instructions if necessary.

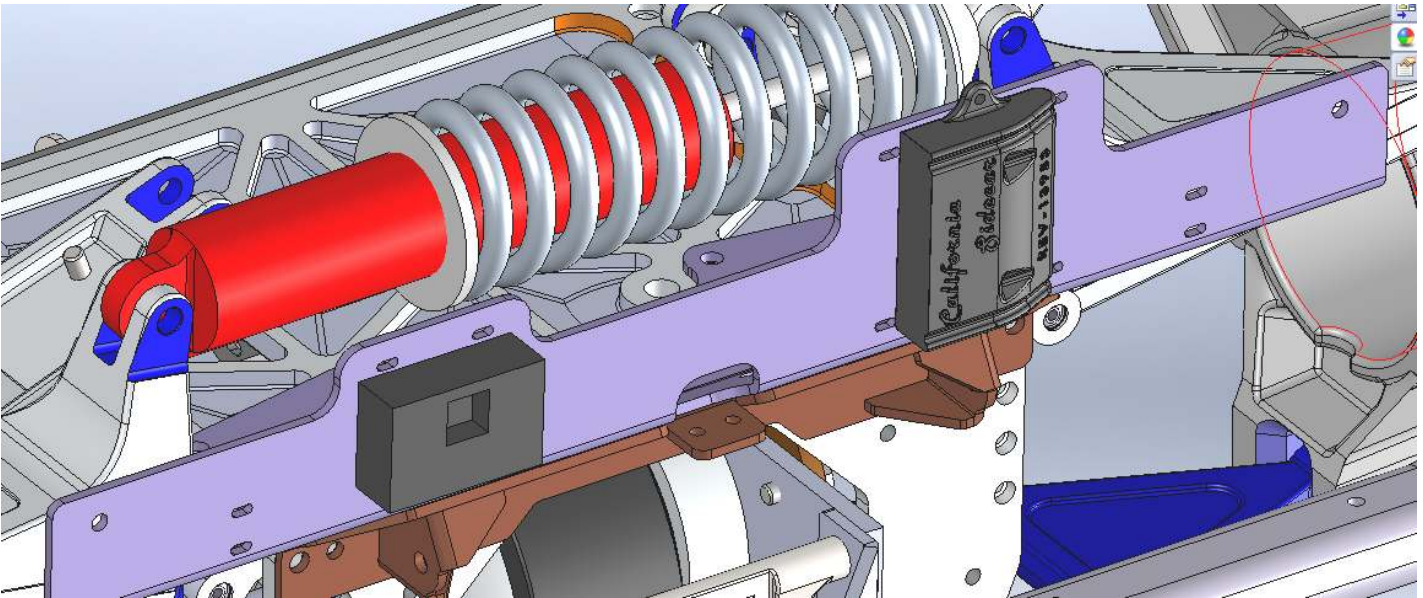

2. Install the passenger seat hook removed from the rear fender. Not provided on a Vaquero. Using two 1/4-20 x 1 1/4 BHSCS and two fender washers and nyloc nuts. Be sure to seal the holes as they go into the trunk.
3. Vaquero models: Remove the seat release lock and install onto the CSC lock plate adapter with OEM fasteners. Skip to step 5.
4. Remove the seat release lock and cable from the left side cover.
5. Install onto the inside left of the body. Secure the lock with two 10-24 nyloc nuts.
6. Lower the body onto the trike with the front of the body pointing downward until it comes to rest onto the upper tray and body frame.
7. Install the passenger floorboards with OEM hardware.

Trike Body alignment:

- 1. The trike body can move left, right, forward, backward, up, down, and angled. Shimming with the provided 1/4 and 1/8 rubber washers may be required to get the trike body into alignment.**
- 2. Raise the front of the body to obtain the vertical location around the motorcycle frame and around the exhaust heat shields.**
- 3. Then slide the body front to back to get the horizontal location. Using the passenger floorboards as a guide.**
- 4. With the body temporarily held into place, raise the adjustable 90° body support brackets until they seat against the body's inner liner.**
- 5. Tighten the two 5/16 – 18 x 3/4 HHCS and two 5/16 – 18 nyloc nuts on the adjustable 90° support brackets.**
- 6. Center the trike body left to right with a square measuring the rotors and then align the mufflers.**

Securing the Trike Body:

Note: A small section of trike body carpet has not been glued at the location of the trike body frame mounting tabs to allow removal of the bolts used in shipping, and installation of the trike body mounting hardware. The predrilled bolt holes may need to be enlarged or relocated for trike body attachment to the trike body frame mounting tabs. If relocation is necessary, the preexisting holes will need to be sealed with silicone sealant.

- 1. Using a 5/16 twist drill, drill up through the rear trike body frame mounting tabs.**
- 2. Insert two 5/16–18 x 1 1/4 HHCS and fender washers from the top, and rubber washers between the body and**

trike body frame use shims if necessary through the drilled holes.

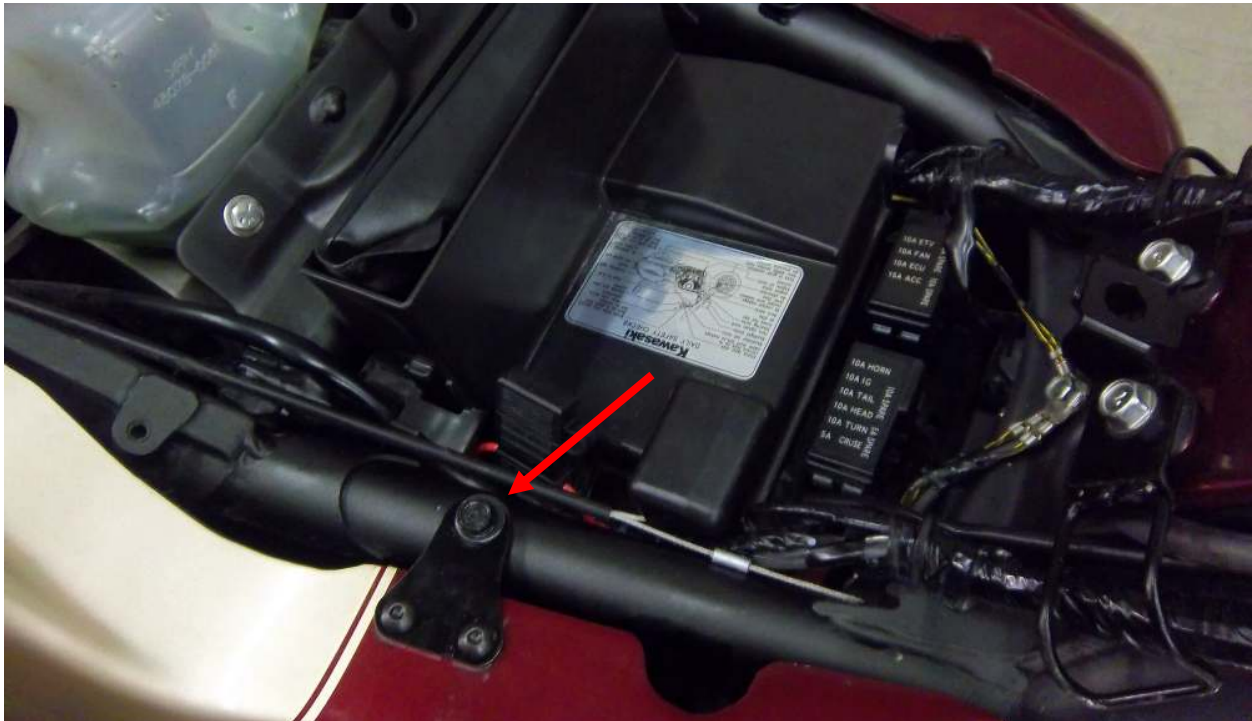

3. Voyager & Nomad: Install the body mount tab to the bosses on the frame as shown. Use OEM hardware.
4. Drill two 1/4 holes through the bracket and secure with two BHCS, fender washers, and nyloc nuts. You can raise the front of the body in order to tighten the fasteners.
5. Reinstall the OEM fasteners and tighten.
6. Reinstall the three exhaust heat shields.
7. With the heat shields install make sure your gap around them is correct. Adjust if necessary.
8. Using a 5/16 twist drill, drill up through the adjustable 90° body support brackets.
9. Insert two 5/16-18 x 1 1/4 HHCS and fender washers through the adjustable 90° body support brackets.
10. Install two nyloc nuts and flat washers onto the HHCS screws and tighten.
11. Re-align the mufflers into the trike body cutout and tighten hardware.

Tour Pak Installation: Voyager models:

- 1. Using the tour box mount plate as a template, mark the area of chrome to be trimmed.**



- 2. Trim away the area marked.**
- 3. Install the two chrome side pieces/LED taillight assembly to the tour pak mount plate with four OEM phillips.**

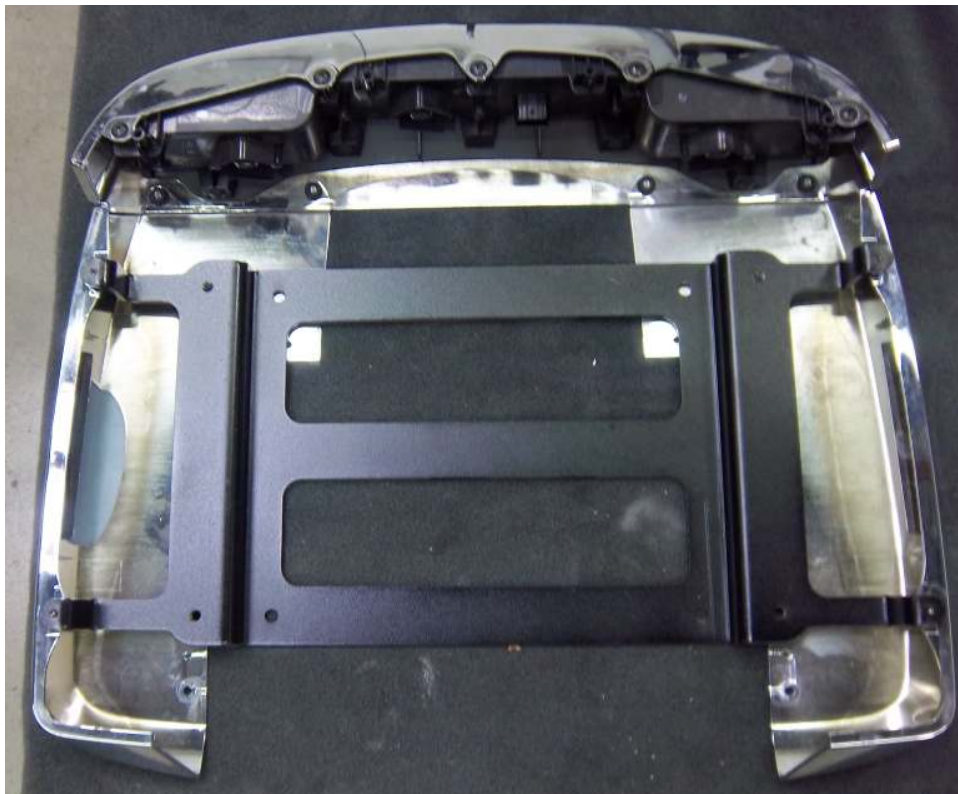

4. Install the tour pak mount plate to the body using four 5/16-18 x 1 1/4 HHCS with flat washers and four nyloc nuts with fender washers. Be sure to seal the holes with silicone.
5. Install the tour pak onto its mount plate with four OEM HHCS and four Phillips screws into the taillight. Reconnect the tail light and antenna. Replace the antenna cover.
6. Install the new antenna ground strap to the antenna and route it forward with the antenna cable to the ground block just behind the fuel tank and attach.
7. Install the tour pak liner.

Backrest Pad Installation: Nomad models:

1. Install the OEM Backrest Pad with OEM hardware onto the CSC Backrest.

Vaquero models:

1. Remove the trunk cap with six 1/4-20 HHCS from the inside.
2. Route the antenna cable under the seat and up to the trunk cap.
3. Insert the antenna stud through the trunk cap then install the antenna cable and secure with OEM nut.
4. Put the cable in the groove in the front of the cap silicone the holes in the top of the body and reinstall the trunk cap with previously removed fasteners.

Reassembly of the motorcycle:

- 1. Connect body wiring harness connector under the frame to the rear fender wiring harness connector.**
- 2. Connect the red wire with fuse holder to the positive battery terminal.**
- 3. Reconnect the negative battery terminal with the new white wire from the trike body wiring harness.**

Final Reassembly of the motorcycle:

- 1. Install the wheel spacers with the flat surface towards the brake rotor if provided. (only with 9-spoke wheels)**
- 2. Reinstall the wheel and tire assemblies with ten m12 x 1.5 ET conical lug nuts. Torque to 65 FT-LBS. 28 PSI.**

Refer to the Maintenance Schedule on p. 4 for details regarding future service inspections and maintenance.

From all of us at California Sidecar.

Enjoy the ride.