



TRIKE CONVERSION KIT

2004 - CURRENT

HARLEY-DAVIDSON
SPORTSTER

INSTALLATION
INSTRUCTIONS

REVISED 1 - 2012

CALIFORNIA SIDECAR PARTS & TECHNICAL SUPPORT
434.263.8866

Table of contents:

1. Warnings and Considerations	3
2. Recommended Lubricants and Sealants	3
3. Maintenance Schedule	4
4. Disassembly of Motorcycle	5
5. Modification of Frame	6
6. Rear Suspension Unit Installation	6
7. Frame Mount Installation	7
8. Brake line Installation	8
9. Bleeding the Brake System	9
10. Exhaust Mount Installation	10
11. Exhaust Tailpipe and Muffler Installation	11
12. Gravel Pan Installation	12
13. Link to CSC Belt Tensioning Video	13
14. Setting up the Sonic Tension Meter	13
15. Using the Sonic Tension Meter	13
16. Tensioning the Front Drive Belt	14
17. Tensioning the Rear Drive Belt	15
18. Suspension Setup	17
19. Trike Body Installation	19
20. Trike Body Alignment	19
21. Securing the Trike Body	19
22. Reassembly of the Motorcycle	21
23. Final Reassembly of the Motorcycle	21

Warnings and Considerations:

- 1. Disclaimer** - These instructions assume a level of understanding of motorcycle repair and maintenance beyond that of a “beginner” and/or “novice” and California Sidecar cannot be liable for an installer’s failure to understand or follow these instructions as written. Likewise, California Sidecar cannot be responsible if any of the steps are omitted or shortcuts are taken, or parts other than those supplied by California Sidecar, are used in installing this trike kit.
- 2. “WARNINGS”** are all printed in bold type and capitalized. They mean to use extreme care in a given step so as not to damage the part, motorcycle, and/or yourself.
- 3. Always wear safety glasses** when using hand and/or power tools.
- 4. When working in and around the fuel system, always work in a well-ventilated area, free from sparks and open flames.**
- 5. All directional references to the “right side” and the “left side” are as you were seated on the motorcycle.**
- 6. All directional references to “forward” mean to the front of the motorcycle while “back” means the rear of the motorcycle unless otherwise stated.**
- 7. Please consult the appropriate Service Manual for your motorcycle if further detail is necessary.**

Recommended Lubricants and Sealants:

- 1. Molybdenum Disulfide grease for splines (Mobil Grease Moly 52 or equivalent)**
- 2. Multipurpose grease for Zerk fittings.**
- 3. Thread locking compound (Loctite 242 minimum).**
- 4. High temperature Silicone sealant.**

Maintenance Schedule: LEGEND

Frequency (miles)	Daily	4k	8k	12k	16k	20k	24k
Item							
Belts	I	I	I	I	I	T	I
Brake Pads and Rotors [1]		I	I	I	I	I	I
Half Shaft Boots		L	L	L	L	L	L
Wheel Bearings [2]		I	I	I	I	I	I
Wheels and Tires		I	I	I	I	I	I
All Lighting	I						
Tire Pressure [3]	I						
Brake fluid		I	I	R	I	I	R

I: Inspect: clean, lubricate, and/or replace as necessary.

R: Replace

L: Lubricate with Silicone Spray

T: Tension

NOTE:

[1] Minimum pad thickness is 0.04 inches (1.02mm)

[2] Wheel bearing torque 200 FT.-LBS.

[3] Rear tire pressure 28 PSI

At higher odometer readings, repeat at frequency intervals established here.

Note:

This Schedule is in addition to the Harley Davidson Maintenance Schedule

NOTICE:

The remote door opener installed on this unit has a very small electrical draw on your motorcycle battery. If your trike will be unriden for more than 2 weeks you should remove the 15 amp fuse from the red fuse holder located under your seat or right side cover. Another option is using a battery tender.

Disassembly of motorcycle:

- 1. Place the motorcycle on the lift.**
- 2. Place a suitable Jack under the Frame of the Motorcycle and tie down securely.**
- 3. Remove the fasteners that secure the seat. Remove seat.**
- 4. Remove both side covers.**
- 5. Disconnect negative Battery Terminal.**
- 6. If equipped remove Saddle Bags and their hardware.**
- 7. Loosen Muffler Clamp on both Mufflers and other attaching hardware. Remove and discard both Mufflers.**
- 8. Remove rear cylinder heat shield.**
- 9. Loosen rear cylinder head pipe.**
- 10. Remove the sprocket side cover.**
- 11. Remove rear brake linkage at the master cylinder.**
- 12. Remove and discard the muffler mount.**
- 13. Reinstall the rear brake linkage.**
- 14. Remove Passenger Foot pegs or Floorboards.**
- 15. Disconnect the Rear Lamp Wiring Harness.**
- 16. Remove the upper shock bolts.**
- 17. Jack up the rear of the bike another 2 inches.**
- 18. Remove and discard Rear Fender, Fender Support and fasteners.**
- 19. Drain all Brake Fluid from the Rear Brake System.**
- 20. Un-clamp Rear Brake Line from the Rear Fork.**
- 21. Remove and discard the Banjo Bolt and Crush Washers from the Rear Brake Caliper.**
- 22. Remove both Rear Fork Pivot bolts.**
- 23. Push Rear Wheel Assembly forward and slip Rear Belt off of the front Sprocket.**
- 24. Remove and discard rear wheel, rear fork, shocks, caliper and belt as an assembly.**
- 25. Remove and discard Jiffy Stand.**

Modification of frame:

1. Cut frame as shown by the red line. Approximately 1 1/2 behind shock bolt threaded hole.

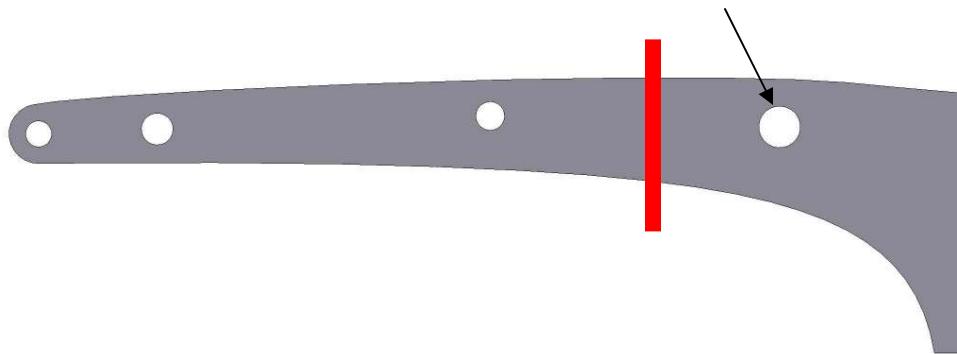

Rear Suspension Unit Installation:

1. Place Suspension Unit using a jack behind prepared motorcycle.
2. Install two frame spacers inside of the upper shock threaded holes.
3. Slide Suspension Unit forward past the pivot bolt alignment for belt installation.
4. Install the front drive belt onto the Drive sprocket then the transmission sprocket.
5. Align and install Rear Fork Pivot bolts but leave loose.
6. Install two 1/2-13 x 3 1/4 HHCS and flat washer thru the intermediate mount bosses though the frame spacers and thread into the frame from the inside out using thread locking agent. Leave loose.
7. Reinstall the chrome front belt cover using OEM hardware and a thick washer on the lower bolt.

Frame Mount Installation:

1. Install the left frame mount over the passenger peg mount bosses.
2. Using two 3/8-16 x 1 3/4 SHCS install them into the upper and lower tabs on the suspension unit.
3. Thread two black 3/8-16 x 1 1/4 SHCS into the frame at the passenger peg mount location. Use thread locking agent.
4. Install the two flat washers and nyloc nuts on the rear tabs.
5. Repeat for the right side.
6. Now torque all fasteners. The four SHCS in the front 40 FT-LBS. Four SHCS with nyloc nuts at the rear 40 FT-LBS. The two HHCS in the intermediate mount 80 FT-LBS. The two pivot bolts. Torque to factory spec.
7. Tighten rear differential support plate hangers. Refer to the red arrows below.

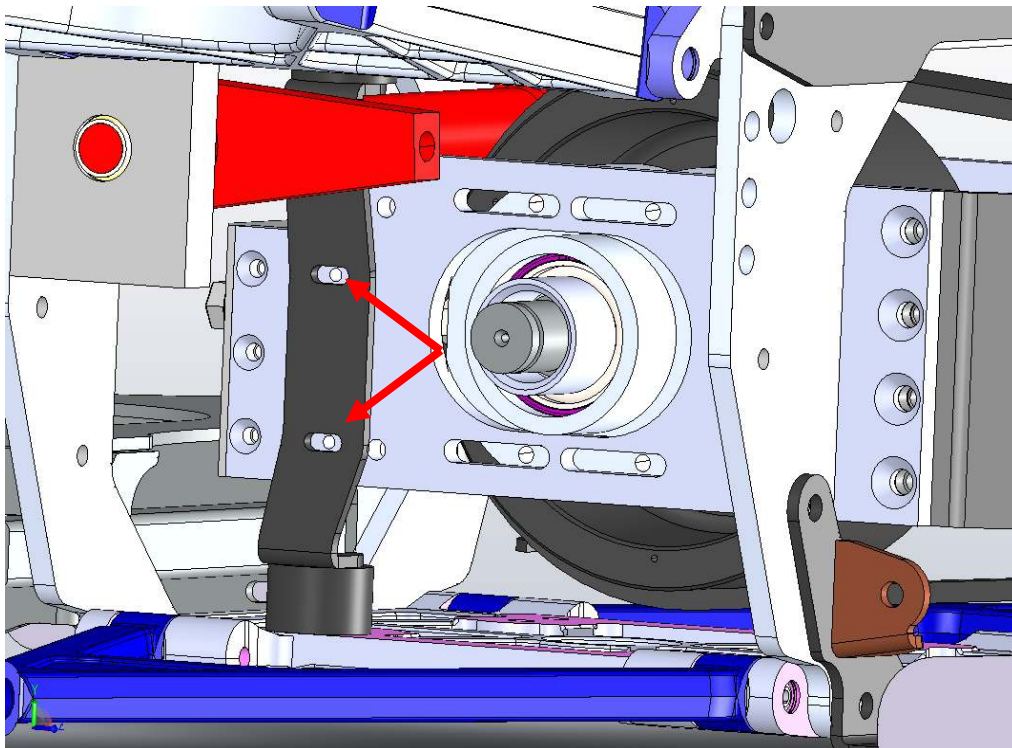

Brake Line Installation:

- 1. Using a new Banjo Bolt and two Crush Washers, install the banjo fitting onto the Distribution Block.**
- 2. Use Cable Ties to secure the Rear Brake Hose to the Frame.**
- 3. Install the master cylinder reservoir relocation bracket to the frame with the OEM bolt and the reservoir to the bracket with a 1/4-20 x 5/8 SHCS.**

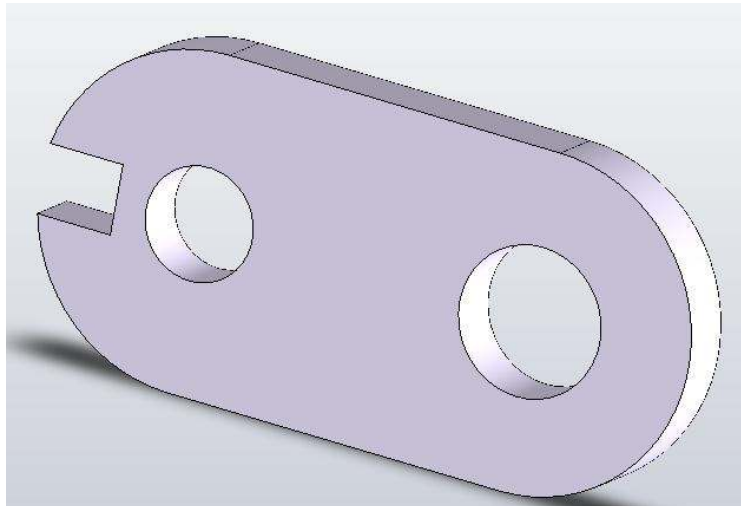

Brake bleeding procedure:

- 1. Using correct brake fluid, fill Rear Brake Master Cylinder Reservoir.**
- 2. Using a vacuum bleeder, follow this procedure **carefully**.**
 - a. Rear caliper rear bleed valves outsides first then insides on each side.**
 - b. Rear caliper front bleed valves outsides first then insides on each side.**
- 3. Hand bleed the system using the above sequence. Until all air is removed from the lines.**
- 4. Allow the bike to set for a minimum of 20 minutes and recheck the pedal travel.**
- 5. If there is excessive pedal travel on the first pump, repeat steps 3 and 4.**



Exhaust Mount Installation:

- 1. Place the Left Exhaust Mount against the left side of the Body Frame.**
- 2. The Exhaust Mount Brackets will be towards the rear. Refer to drawing.**

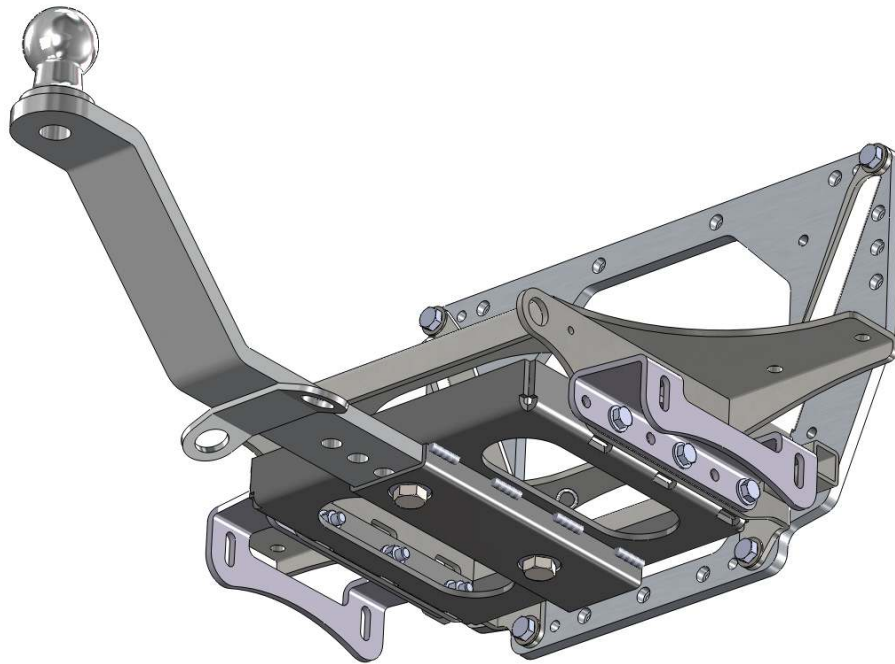

- 3. Using the lower holes. Install three 5/16-18 x 1 1/4 HHCS and three flat washers thru the Exhaust Mount and the Body Frame from the outside in.**
- 4. Install Trailer Hitch now if equipped.**
- 5. Loosely install three flat washers and nyloc nuts.**
- 6. Install the right side with the same procedure.**

Exhaust Tailpipe and Muffler Installation:

1. Slide the Right Rear Tailpipe (short and straight) onto the Rear Head Pipe with one small clamp on the front.
2. Slide the Left Rear Tailpipe (long and bent) onto the Front Head Pipe with one small clamp on the front and two large clamps in the middle.
3. Install the large clamps on the two left tailpipe hanger brackets on the drive support one on each side.

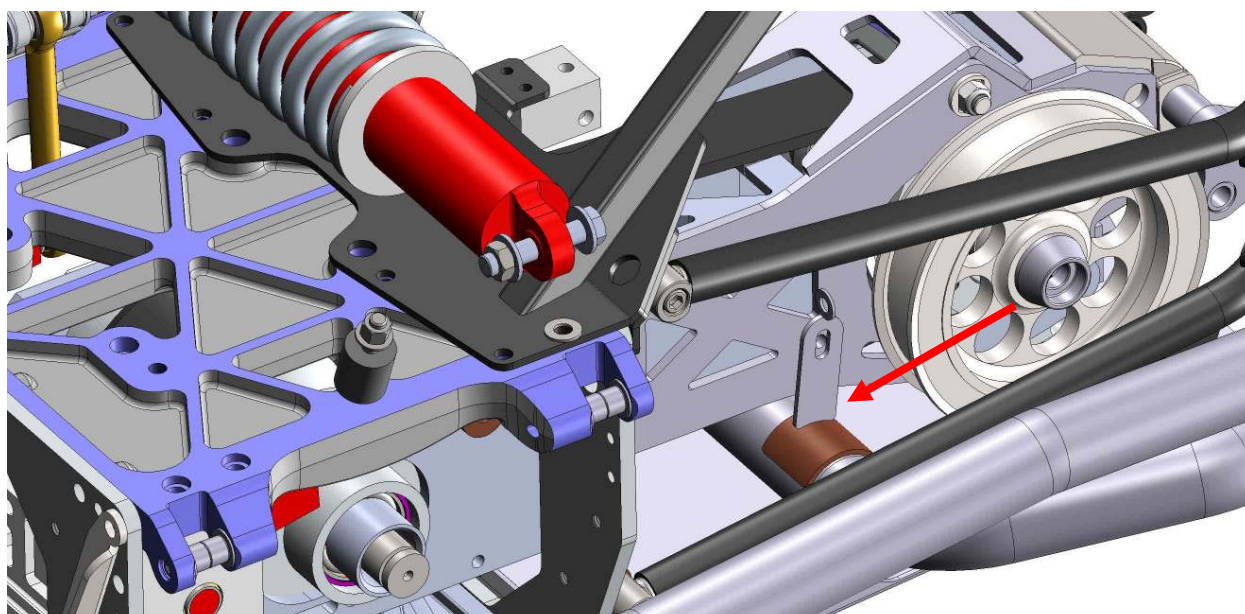

4. Install the rubber sandwich mounts onto the mufflers.
5. Place one large clamp on each muffler and slide the mufflers onto the Left and Right Tailpipes.
Note: Insure there is a 1/2 inch air gap around the inner C.V. joint
6. Loosely install four 5/16-18 nyloc nuts and flat washers to the sandwich mounts on the mufflers.
7. Leave all clamps loose at this time.

Gravel Pan Installation:

1. Install gravel pan with four 1/4-20 HHCS.
2. Install the two in the rear from the bottom up with a flat washer and secure with a flat washer and nyloc nut.
3. Install the two in the front from the outside in with a flat washer and secure with a flat washer and nyloc nut.

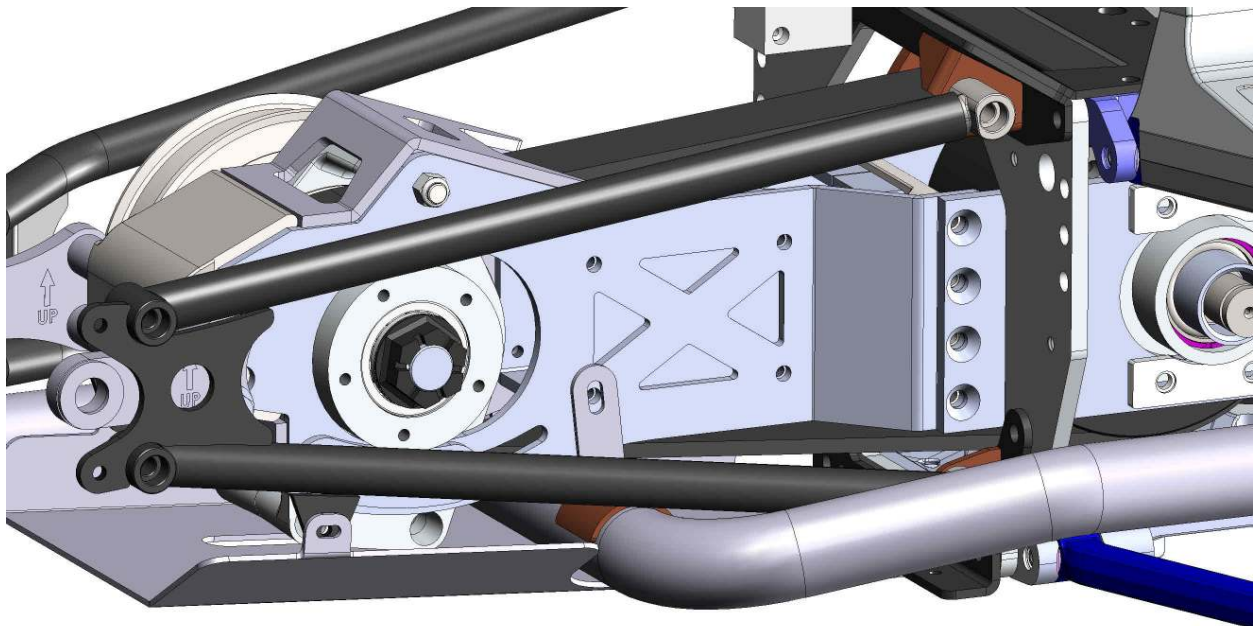

4. Align all exhaust pipes for no interference.
5. Tighten all clamps and the rear head pipe, but leave the muffler loose for vertical alignment later.

Link to CSC Belt Tensioning Video:

<http://www.californiasidecar.com/support.html>

Setting up the Sonic Tension Meter:

1. Turn power on, Push Select then 1.
2. Using the charts below in Front and Rear belt tensioning push Mass then the numbers, Width and so on.
3. For the Rear belt push Select then 2. Reverse belt can be number 3 and so on.

Using the Sonic Tension Meter:

1. The microphone placement over the belt is critical.
 - a. The microphone should be in the middle of the belt width-wise.
 - b. The microphone should be equally in-between the two Sprockets.
 - c. The microphone should be between $\frac{1}{4}$ and $\frac{1}{2}$ an inch above or below the Belt.
2. Turn the Sonic Tension Meter on.
3. Ensure that the correct setting is displayed on the LCD screen.
4. Push MEASURE then gently tap the Belt with a wrench while holding the microphone in the correct position. A measurement in Lbs. of single span tension should display. If not continue tightening the Belt until a reading is displayed.
5. In noisy environments the Sonic Tension Meter may display errant numbers. If so use in a quieter area.
6. Always take at least THREE readings of the Belt tension and average the THREE readings to determine the actual tension of the Belt.

Tensioning the Front Drive Belt:

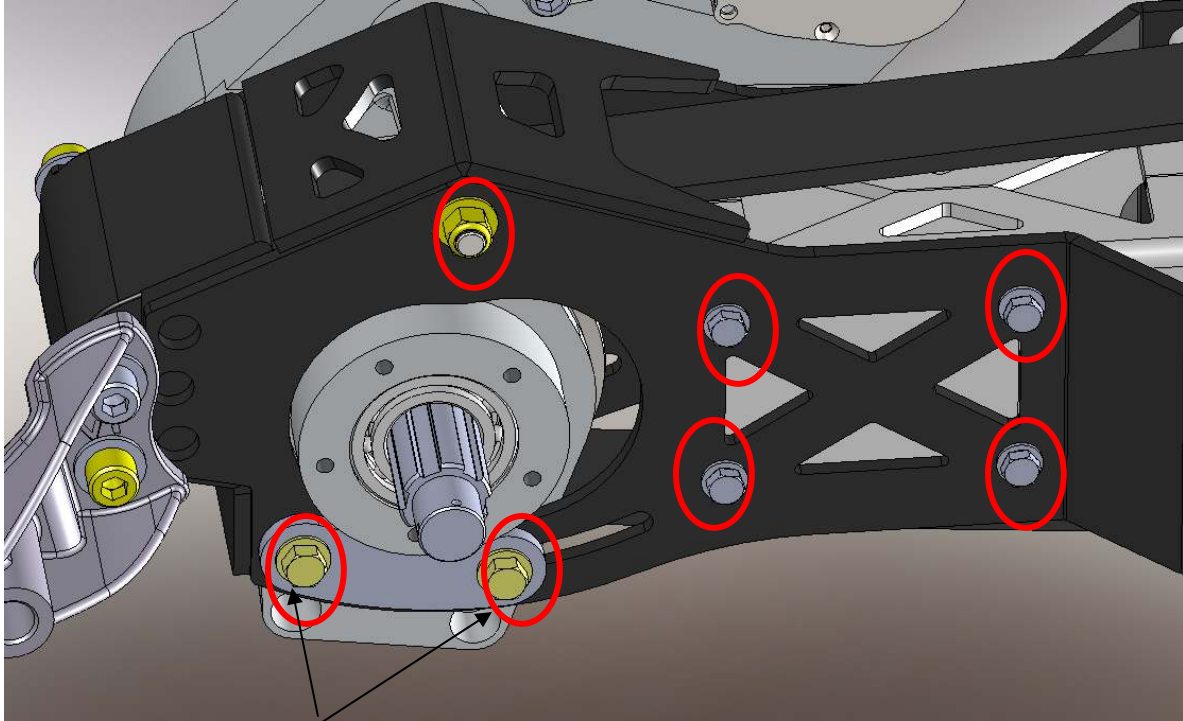

**TWO MORE ON
OTHER SIDE**

1. Loosen the four HHCS in the rear only on the left side. Next loosen the four clamping HHCS two per side and the one upper pivot shaft nyloc nut.
2. Tighten the Rear Drive Belt adjuster nuts until the slack is taken up on the Front Drive Belt.
3. Use the correct setting on the Sonic Tension Meter.
MASS 007.9 g/m
WIDTH 028.0 mm/r
SPAN 348 mm
4. Check Front Drive Belt tension.
Front Belt: 130 - 150 lbs. single span tension.
5. Once the correct belt tension is achieved tighten all fasteners previously loosened in step 1. Eight HHCS and one nyloc nut.
6. Verify belt tension.
7. If incorrect start back at step 1. If correct proceed to Rear Belt Tensioning.

Tensioning the Rear Drive Belt:

1. See diagram.

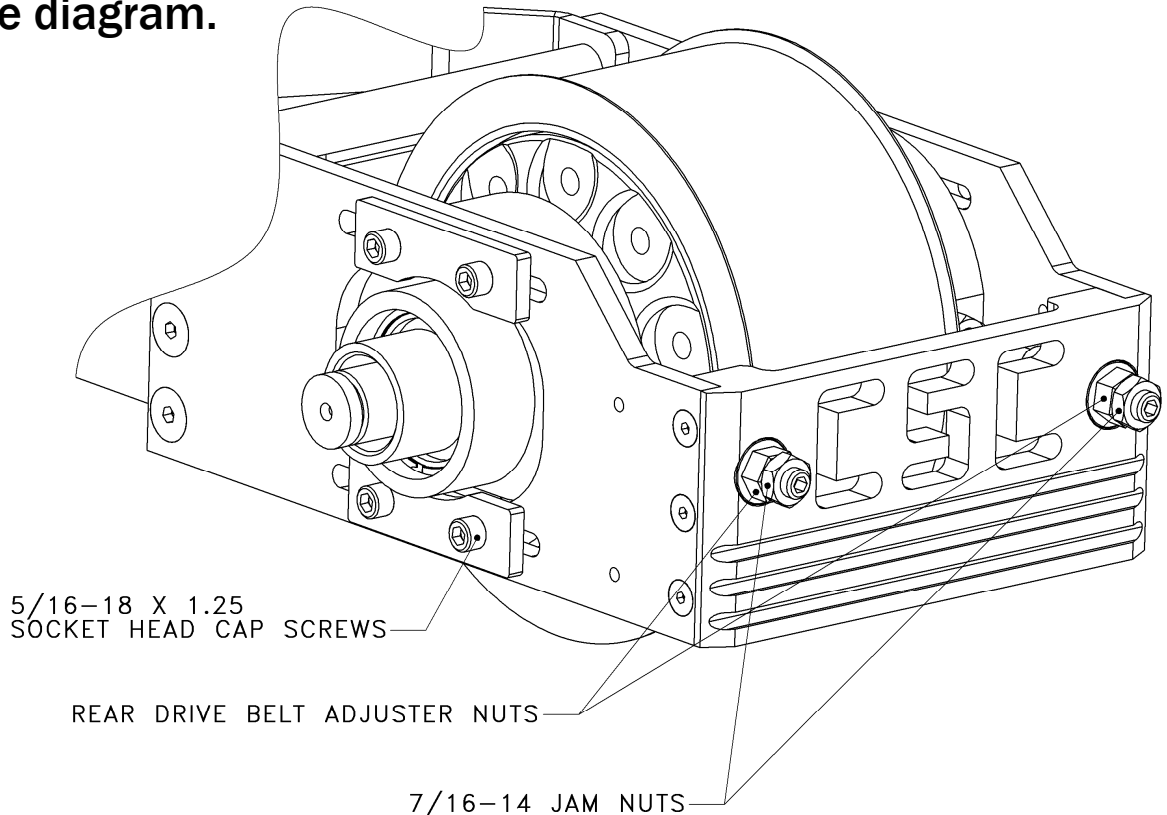

2. Tighten the Rear Drive Belt Adjuster nuts until the slack is taken up on the Rear Drive Belt.

3. Use the correct setting on the Sonic Tension Meter.

50mm wide Belt:

MASS 007.9 g/m

WIDTH 050.0 mm/r

SPAN 0442 mm

4. Check Rear Drive Belt tension.

50mm belt: 130 - 150 lbs. of single span tension.

5. In the next step you are going to run the engine. Please be aware of the safety of all those involved. Make sure you have at least two lug nuts on each rotor and that they are tight.

6. To finish alignment, the belt must have at least 0.040in clearance between edge of belt and fence on front Rear Drive Sprocket. Check this by starting the engine and

placing it in second gear and simply let the engine idle. Checking the alignment by eye and centering the belt as it spins. If belt has correct clearance, go to **step 8**. If it does not have clearance, proceed to **step 7**.

7. Use the Left and Right Rear Drive Belt Adjuster Nuts to align belt in order to achieve the necessary belt clearance. **NOTE:** The belt will always track to the side of the sprocket that is the loosest. Repeat step 4.
8. Once the correct belt alignment and single span tension is achieved, tighten the eight 5/16 - 18 x 1 1/4 SHCS that go into the Carrier Bearing Support Housings.
9. Install two 7/16 - 14 hex jam nuts onto the Rear Drive Belt Tensioning Studs and tighten.
10. Once again verify belt tension and alignment.
11. If all is correct move on to next step. If not loosen clamping bolts and return to step 4.

Service Limits on Drive Belts:

1. Service limit on the Front Drive Belt is 130 - 150 lbs.
2. Service limit on the Rear Drive Belt is 130 - 150 lbs.

Suspension Setup:

Use this chart to select the correct spring preload. Rotate the adjuster nut on the shock until the spring is set to the desired length. Now tighten the set screw on the adjuster nut or tighten the lock nut on the fully adjustable shock.

Load: Typical weight the customer adds to the stock trike. This includes riders, luggage, and weight of a trailer tongue. When in doubt assume a higher weight than actual.

Length: Suggested length the spring should be adjusted to with the suspension completely unloaded and the preloader adjusted all the way out.

Legend					
STANDARD SHOCK					
	LOAD	LENGTH		LOAD	LENGTH
200 LB/IN SPRING	100	11 3/8	250 LB/IN SPRING	100	11 1/2
	200	11		200	11 3/16
	300	10 5/8		300	10 7/8
	400	10 1/4		400	10 9/16
				500	10 1/4
ADJUSTABLE SHOCK					
	LOAD	LENGTH		LOAD	LENGTH
200 LB/IN SPRING	100	10 7/8	250 LB/IN SPRING	100	11 1/16
	200	10 1/2		200	10 3/4
	300	10 1/8		300	10 1/2
	400	9 3/4		400	10 1/8
				500	9 7/8
			600	9 1/2	

1. Install preload adjuster now if equipped. Refer to separate installation instructions.
2. Install Fully Adjustable shock adjuster now if equipped. Refer to separate installation instructions.

These lengths are only estimates. If you would like to confirm a correct setting, load the completed trike to the customers typical riding situation and measure from the ground to the middle of the lower suspension plate. The center hole should be 5.75" – 6.25" from the ground.

Attention: This is the only suspension adjustment needed. All other settings are factory set and should not be tampered with. There is no need to remove trike from the lift to check camber, toe, or the drop links.

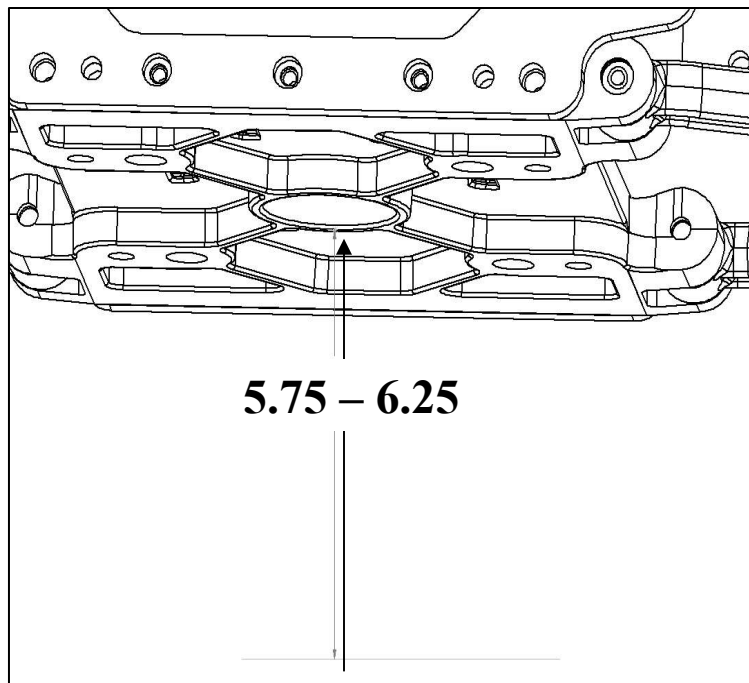

Trike Body installation:

1. Lower the body onto the trike with the front of the body pointing downward until it comes to rest onto the upper tray and body frame.

Trike Body alignment:

1. The Trike Body can move left, right, forward, backward, up, down, and angled. Shimming with the provided 1/4 and 1/8 Rubber Washers may be required to get the Trike Body into alignment.
2. Install both side covers.
3. Set the seat in place. Using the threaded insert in the body to help with body alignment
4. Raise the front of the body to obtain the vertical location around the side covers.
5. Then slide the body front to back to get the horizontal location. Again align with the side covers and the seat.
6. With the body temporarily held into place, raise the adjustable 90° body support brackets until they seat against the body's inner liner.
7. Tighten the two 5/16 – 18 x 3/4 HHCS and nyloc nuts on the Adjustable 90° Support Brackets.
8. Center the Trike Body left to right measuring off the rotors.

Securing the trike body:

Note: A small section of Trike Body Carpet has not been glued at the location of the Trike Body Frame mounting tabs to allow removal of the bolts used in shipping, and installation of the Trike Body mounting hardware. The predrilled bolt holes may need to be enlarged or

relocated for Trike Body attachment to the Trike Body Frame mounting tabs. If relocation is necessary, the preexisting holes will need to be sealed with silicone sealant.

1. Using a 5/16 twist drill, drill up through the Trike Body Frame mounting tabs.
2. Insert 5/16-18 x 1 1/4 HHCS, fender washer, and rubber washers if necessary through the holes drilled.
3. Install nyloc nuts and flat washers onto the rear HHCS and tighten.
4. Using a 5/16 twist drill, drill up through the Adjustable 90° Body Support Brackets.
5. Insert 5/16-18 x 1 1/4 HHCS and fender washers through the adjustable 90° body support brackets.
6. Install nyloc nuts and flat washers onto the front HHCS and tighten.
7. Re-align the Mufflers and tighten hardware.
8. Install Passenger peg mounts with OEM hardware.

Reassembly of the motorcycle:

1. Replace the 15 AMP “lights” fuse with the 20 AMP fuse provided.
2. Connect Body Wiring Harness connector under the Frame to the Rear Fender Wiring Harness Connector.
3. Connect the red wire with Fuse Holder to the Positive Battery terminal.
4. Reconnect the negative battery terminal and the new white wire from the Trike Body Wiring Harness.

NOTE: It is necessary for the LED tail lights that the white wire goes directly to the battery ground and not just to the chassis ground.

5. Replace the Seat with OEM hardware.

Final Reassembly of the motorcycle:

1. Reinstall the wheel and tire assemblies with ten m12 x 1.5 ET conical lug nuts. Torque to 65 FT-LBS.

Refer to the Maintenance Schedule on p. 4 for details regarding future service inspections and maintenance.

**From all of us at California Sidecar.
Enjoy the ride.**

