



TRIKE CONVERSION KIT

2000 - CURRENT

FLST HARLEY-DAVIDSON

INSTALLATION
INSTRUCTIONS

Revised 1 - 2012

CALIFORNIA SIDECAR PARTS & TECHNICAL SUPPORT
434.263.8866

Table of contents:

1. Warnings and Considerations	3
2. Maintenance Schedule	4
3. Recommended Lubricants and Sealants	4
4. Disassembly of Motorcycle	5
5. Front Drive Belt Installation 5 speed	8
6. Front Drive Belt Installation 6 speed	13
7. Modification of Frame	15
8. Rear Suspension Unit Installation	17
9. Brake Line Installation	17
10. Bleeding the Brake System	18
11. Frame Mount Installation	19
12. Gravel Pan Installation	19
13. Exhaust Mount Installation	20
14. Trailer Hitch Installation	20
15. Exhaust Head Pipe Installation	20
16. Exhaust Tailpipe and Muffler Installation	21
17. Link to CSC Belt Tensioning Video	22
18. Setting up the Sonic Tension Meter	22
19. Using the Sonic Tension Meter	22
20. Tensioning the Front Drive Belt	23
21. Tensioning the Rear Drive Belt	24
22. Suspension Setup	25
23. Trike Body Installation	27
24. Trike Body Alignment	27
25. Securing the Trike Body	28
26. Reassembly of the Motorcycle	29
27. Final Reassembly of the Motorcycle	30

Warnings and Considerations:

1. **Disclaimer** - These instructions assume a level of understanding of motorcycle repair and maintenance beyond that of a “beginner” and/or “novice” and California Sidecar cannot be liable for an installer’s failure to understand or follow these instructions as written. Likewise, California Sidecar cannot be responsible if any of the steps are omitted or shortcuts are taken, or parts other than those supplied by California Sidecar, are used in installing this trike kit.
2. **“WARNINGS”** are all printed in bold type and capitalized. They mean to use extreme care in a given step so as not to damage the part, motorcycle, and/or yourself.
3. **Always** wear safety glasses when using hand and/or power tools.
4. When working in and around the fuel system, **always** work in a well-ventilated area, free from sparks and open flames.
5. All directional references to the “right side” and the “left side” are as you were seated on the motorcycle.
6. All directional references to “forward” mean to the front of the motorcycle while “back” means the rear of the motorcycle unless otherwise stated.
7. Please consult the appropriate Service Manual for your motorcycle if further detail is necessary.

Maintenance Schedule: VOLUSIA

Frequency (miles)	Daily	4k	8k	12k	16k	20k	24k
Item							
Belts	I	I	I	I	I	T	I
Brake Pads and Rotors [1]		I	I	I	I	I	I
Half Shaft Boots		L	L	L	L	L	L
Wheel Bearings [2]		I	I	I	I	I	I
Wheels and Tires		I	I	I	I	I	I
All Lighting	I						
Tire Pressure [3]	I						
Brake fluid		I	I	R	I	I	R

I: Inspect: clean, lubricate, and/or replace as necessary.

R: Replace

L: Lubricate with Silicone Spray

T: Tension

NOTE:

[1] Minimum pad thickness is 0.04 inches (1.02mm)

[2] Wheel bearing torque 200 FT.-LBS.

[3] Rear tire pressure 28 PSI

At higher odometer readings, repeat at frequency intervals established here.

Note:

This Schedule is in addition to the Harley Davidson Maintenance Schedule

Recommended Lubricants and Sealants:

1. Molybdenum Disulfide grease for splines (Mobil Grease Moly 52 or equivalent)
2. Multipurpose grease for Zerk fittings.
3. Thread locking compound (Loctite 242 minimum).
4. High temperature Silicone sealant.

Disassembly of motorcycle:

- 1. Place the motorcycle on the lift.**
- 2. Place a suitable Jack under the Frame of the Motorcycle and tie down securely.**
- 3. Remove Drain Plug from Primary Cover Assembly and drain oil.**
- 4. Slide Rubber Boot off of the Clutch Cable Adjuster. Loosen and back the Jam nut away from the Clutch Cable Adjuster. Move Clutch Cable Adjuster towards the Jam Nut to introduce free play in the Clutch Lever.**
- 5. Remove the fasteners that secure the seat. Remove seat.**
- 6. Disconnect negative Battery Terminal.**
- 7. Remove the Saddle Bags. And their hardware. If equipped.**
- 8. Loosen Muffler Clamp on both Mufflers and other attaching hardware. Remove and discard both Mufflers.**
- 9. Loosen the 4 exhaust stud nuts and save. Remove and discard head pipes and exhaust gaskets.**
- 10. Disconnect the Rear Lamp Wiring Harness.**
- 11. Remove any fasteners from Electrical Box.**
- 12. Remove and discard Rear Fender, Fender Support and fasteners.**
NOTE: 2008-Current Fatboy Only: Remove ECM from Fender and save nuts.
- 13. Drain all Brake Fluid from the Rear Brake System.**
- 14. Un-clamp Rear Brake Line from the frame and Rear Fork.**
- 15. Remove and discard both Banjo Bolts and Crush Washers from the Rear Brake Caliper and the Rear Brake Master Cylinder.**
- 16. Remove Brake Light Switch from the Brake line. Save for reassembly.**

- 17. Remove the Torx screw from the Brake Line bracket.
Save the Torx screw for reassembly.**
- 18. Remove and Discard Brake Line.**
- 19. Remove and discard belt guard and debris deflector from rear fork.**
- 20. Remove and discard the Spring Clip and nut from the Rear Axle.**
- 21. Remove and discard Rear Axle and Rear Wheel Spacers.**
- 22. Push Rear Wheel Assembly forward and slip Rear Belt off of the Rear Sprocket.**
- 23. Remove Rear Brake Caliper.**
- 24. Remove Rear Wheel Assembly.**
- 25. Remove Passenger Foot pegs or Floorboards.**
- 26. Remove the two Rear shocks nuts and the rubber bushings.**
- 27. Remove nut and washer from Rear Fork Pivot Shaft.**
- 28. Remove Rear Fork Pivot Shaft and rear shocks.**
- 29. Remove and discard two spacers between transmission and Rear Fork and two spacers from the inside of the spherical bearings.**
- 30. Remove and discard the Rear Fork.**
- 31. Remove acorn nut from Shift Linkage.**
- 32. Remove 3 fasteners from Drivers Floorboard and remove.**
- 33. Remove and discard Jiffy Stand.**
- 34. Remove the Primary Cover by first removing the top and rear inspection cover screws.**
- 35. Continue by removing remaining fasteners. 14 total.**
- 36. Remove and discard Primary Cover Gasket.**
- 37. Clean residual gasket material from both surfaces.**
- 38. Loosen the Top Center Nut on the Primary Chain Adjuster. Lower the Primary Chain Adjuster until it rests flat on the Inner Primary Cover.**

39. Remove the Clutch Lifter Retaining Ring from the Clutch Basket. Remove Clutch Lifter Assembly.
 40. Using the Primary Drive Locking Tool. Loosen the Compensating Sprocket Nut.
 41. Using the Primary Drive Locking Tool. Loosen the Clutch Hub Main shaft Nut. **WARNING:** This nut is LEFT HAND threaded.
 42. Remove the Primary Drive Locking Tool, Compensating Sprocket Nut, and Clutch Hub Main shaft Nut.
 43. Remove the Sprocket cover and Sliding Cam from the Crank Shaft Extension.
 44. Remove the Clutch Assembly, Primary Chain, Compensating Sprocket, and Crank Shaft Extension in one assembly.
 45. Bend tab on the Starter Jack Shaft bolt Locking Plate away from the head of the Jack Shaft Bolt. Holding the Pinion Gear remove the Jack Shaft Bolt, Lock Plate, and Thrust Washer.
 46. Remove the Starter Jack Shaft Assembly from the Primary Chain case.
 47. Bend lock plate tabs back where necessary and remove primary-to-engine mounting bolts first, next remove primary-to-transmission mounting bolts.
 48. Remove the 2 starter bolts.
 49. Remove Primary Chain case and discard the o-ring or gasket.
 50. Remove the Final Drive Belt.
- NOTE: 2000 – 2003 MODELS:** continue below.
- NOTE: 2004 – UP: Do not remove the Drive Sprocket.**
- 2004 – 2006** Skip to “Front Drive Belt Installation”.
- 2007 – UP:** Skip to “Front Drive Belt Installation” PAGE 13.
51. Remove both screws and Locking Plate.
 52. Lock Sprocket with the Sprocket Locking Tool.

53. Using Special deep well socket and pilot, remove the left hand threaded Sprocket Lock Nut, and Pilot.
54. Remove the Sprocket From the Main Shaft.
55. Slide New Drive Sprocket onto the splines of the Main Shaft if required.
56. Lock Final Drive Sprocket with the Sprocket Locking Tool.
57. Apply Loctite 262 to the threads of the Final Drive Sprocket Nut.
58. Finger tighten the left hand threaded Final Drive Sprocket nut.
59. Using Special Deep Well Socket and Pilot. Tighten the Final Drive Sprocket Nut to 60 Ft-Lbs initial torque.
60. Scribe a straight line on the Final Drive Sprocket Nut and Final Drive Sprocket.
61. Tighten the Final drive Sprocket Nut an additional 35° to 40° (45° MAXIMUM).
62. Place the Lock Plate over the Final Drive Sprocket Nut and align the holes in the Lock Plate with the two tapped holes in the Sprocket. If these two holes do not line up continue tightening the Final Drive Sprocket Nut to 45° maximum.
63. Reinstall the 2 screws with thread locking agent through the Lock Plate into the Final Drive Sprocket and torque to 84 - 108 In-Lbs.

2000 – 2006: 5 Speed Front Drive Belt Installation:

1. Install new Primary Final Drive Belt onto the Final Drive Sprocket.
2. Using a cloth strip Slightly compress the Primary Final Drive Belt until the Primary final Drive Belt is parallel coming off of the Final Drive Sprocket and tie. **WARNING: DO NOT OVER CRIMP THE PRIMARY FINAL DRIVE BELT.**
3. Install new Crank Case O-Ring or gasket onto the Crank Case.

4. Apply silicone sealant to the Crank Case around the two rearward holes.
5. Apply silicone sealant to the Transmission Case around all 4 holes.
6. Apply silicone sealant to the threads of the 6 bolts with Lock tabs.
7. Place the Primary Chain Case into position over the Crank Case and against the Transmission Housing.
8. Start the 2 bolts with flat washers into the 2 outer holes and the remaining 6 bolts with Lock tabs into the inner holes of the Primary Chain Case.
9. Tighten inner primary chaincase screws 1-8 to **17-21 ft-lbs** in the sequence shown below.

Inner Primary Chaincase

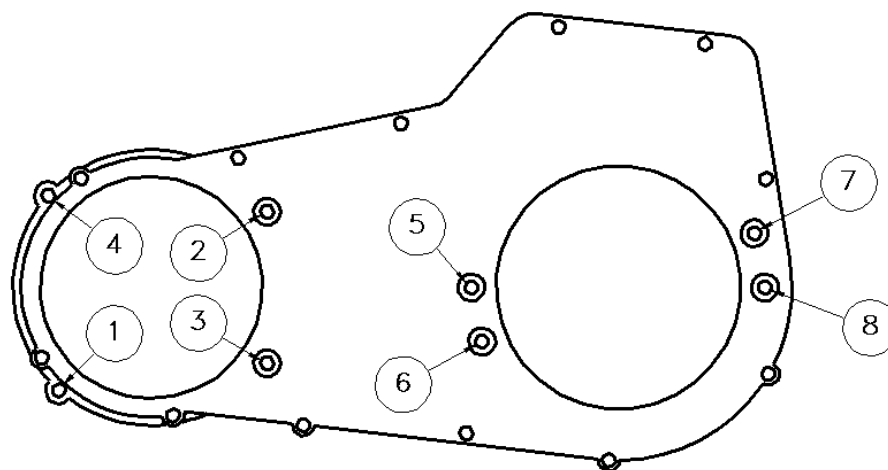

10. Bend Lock tabs into place.
11. Place starter into position.
12. Insert the Starter Jack Shaft Assembly into the splined Coupling.
13. Insert the Jack Shaft Bolt into the Starter Jack Shaft. Ensure the key on the Lock Plate aligns with the slot. While holding the Pinion Tighten the Jack Shaft Bolt to **60-80 in-lbs.**

- 14. Bend tab on the Lock Plate against flat on the Jack Shaft Bolt.**
- 15. Install Alternator Rotor Spacer onto the Engine Sprocket Shaft if present.**
- 16. Install the Clutch, Primary Chain, compensating Sprocket, and Shaft Extension as one assembly. Start the Clutch onto the Main Shaft first. Then align the splines of the Engine Sprocket Shaft with the splines in the Shaft Extension. Now align the splines in the Clutch with the splines on the Main Shaft.**
- 17. Clean off old Loctite then apply two drops of Loctite 262 to the threads of the Compensating Sprocket Nut and Clutch Hub Main Shaft Nut.**
- 18. Install the Sliding Cam and Sprocket Cover onto the Shaft Extension. Install the Compensating Sprocket Nut and hand tighten.**
- 19. Install the LEFT HAND threaded Clutch Hub Main Shaft Nut and hand tighten.**
- 20. Ensure the Primary Chain Adjuster is resting flat on the Inner Primary Cover.**
- 21. Using the Primary Drive Locking Tool. Tighten the Compensating Sprocket Nut to 75 ft-lbs.**
- 22. Tighten the sprocket nut an additional 45 to 50 degrees. (50 degrees MAXIMUM)**
- 23. Using the Primary Drive Locking Tool. Tighten the Clutch Hub Main Shaft Nut to 70–80 ft-lbs. **WARNING:** This nut is LEFT HAND threaded.**
- 24. Remove the Primary Drive Locking Tool.**
- 25. Adjust free play in the Primary Chain by raising the Primary Chain Adjuster Shoe until there is only 5/8 – 7/8 inches of free play on the center of the upper strand. Once free play measurement is achieved tighten the Primary Chain Adjuster Captive Bolt to 25 ft-lbs.**

- 26. Place the Clutch Release Plate into the Clutch with the stamped word “OUT” facing outwards.**
- 27. Install the Retaining Ring into the bore of the Clutch Hub. Ensure the Retaining Ring is fully seated in to the Clutch Hub groove.**
- 28. Loosen Lock Nut on the Clutch Adjuster Screw.**
- 29. Turn the Clutch Adjuster Screw inwards until lightly seated.**
- 30. Back out Clutch Adjuster Screw $\frac{1}{2}$ to 1 turn. While holding the Clutch Adjuster Screw from turning, tighten the Clutch Adjuster Screw Jam Nut to 72–120 in-lbs.**
- 31. Squeeze the Clutch Lever 3 times to its maximum limits.**
- 32. Move Clutch Cable Adjuster away from the Jam Nut to remove free play in the Clutch Lever.**
- 33. Adjust Clutch Cable free play until there is $\frac{1}{16}$ to $\frac{1}{8}$ inch gap between the Clutch Cable ferrule and Clutch Lever Bracket.**
- 34. Tighten the Clutch Cable Adjuster Jam Nut. Slide the Rubber Boot over the Clutch Cable Adjuster.**
- 35. Hang new Primary Chain Case Cover Gasket on Dowels.**
- 36. Install the Outer Primary Chain Case Cover over the Primary Chain Case Cover Gasket.**
- 37. Tighten primary cover screws 1-12 to 108-120 in-lbs in the sequence shown below.**

Primary Chaincase Cover

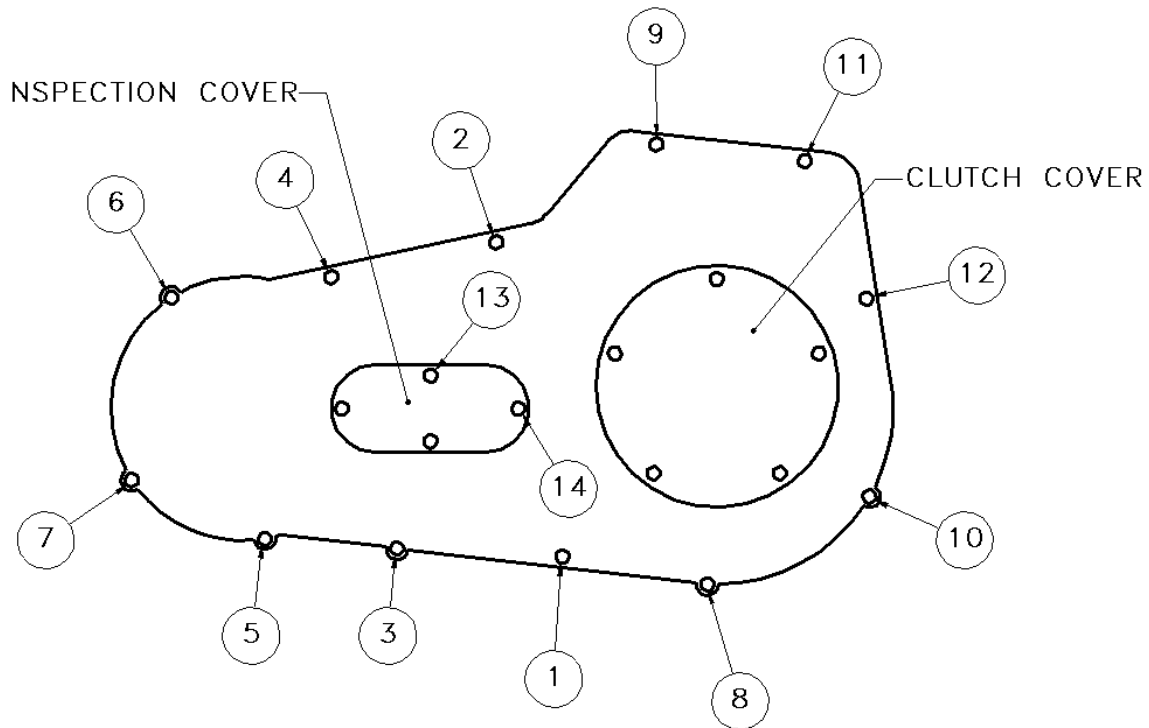

- 38. Remove the 2 bolts still in the inspection cover. Remove and discard gasket.**
- 39. Apply thread sealant to the Drain Plug and reinstall.**
- 40. Fill the Primary Chain case with 32 oz. of the appropriate lubricant.**
- 41. Install new inspection cover gasket and Torque cover screws to 84-108 In-Lbs.**
- 42. Reinstall Driver Floorboard and Shifter linkage with previously removed fasteners.**

2007- Current 6 Speed Front Drive Belt Installation:

1. Install new Front Drive Belt.
2. Install new inner primary gasket with two white plastic tree clips saved from before.
3. Reinstall the inner primary and its fasteners. Torque to the 25–27 ft-lbs in the sequence below.

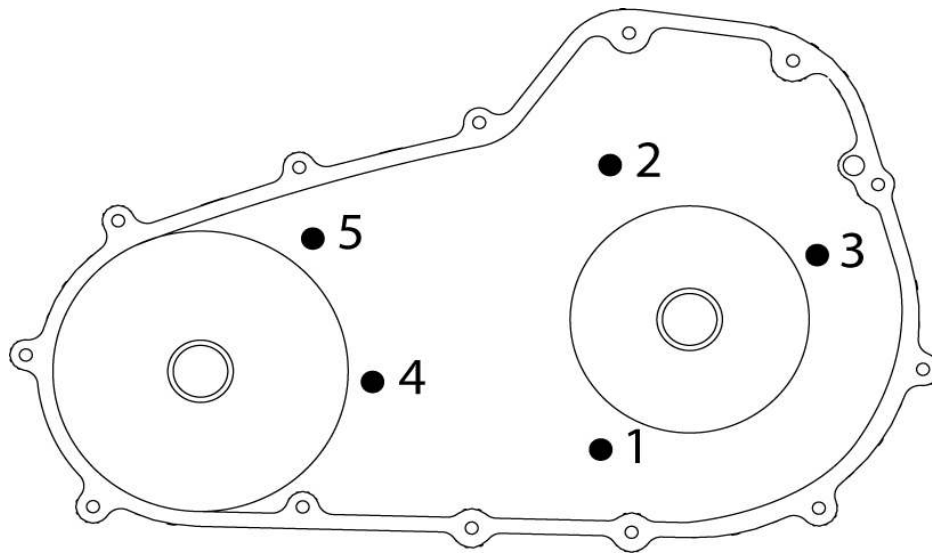

4. Place starter into position and tighten the two fasteners.
5. Install the Clutch, Primary Chain, compensating Sprocket, and Shaft Extension as one assembly. Start the Clutch onto the Main Shaft first. Then align the splines of the Engine Sprocket Shaft with the splines in the Shaft Extension. Now align the splines in the Clutch with the splines on the Main Shaft.
6. Clean off old Loctite then apply two drops of Loctite 262 to the threads of the Compensating Sprocket Bolt and Clutch Hub Main Shaft Nut.
7. Install the Compensating Sprocket Bolt and hand tighten.
8. Install the LEFT HAND threaded Clutch Hub Main Shaft Nut and hand tighten.

9. Using the Primary Drive Locking Tool. Torque the Compensating Sprocket Bolt to 100 ft-lbs then loosen bolt one full turn. Then final torque is 140 ft-lbs.
10. Using the Primary Drive Locking Tool. Torque the Clutch Hub Nut to 70–80 ft-lbs. **WARNING:** This nut is **LEFT HAND** threaded.
11. Remove the Primary Drive Locking Tool.
12. Place the Clutch Release Plate into the Clutch with the stamped word “OUT” facing outwards.
13. Install the Retaining Ring into the bore of the Clutch Hub. Ensure the Retaining Ring is fully seated in to the Clutch Hub groove.
14. Loosen Lock Nut on the Clutch Adjuster Screw.
15. Turn the Clutch Adjuster Screw inwards until lightly seated.
16. Back out Clutch Adjuster Screw $\frac{1}{2}$ to 1 turn. While holding the Clutch Adjuster Screw from turning, tighten the Clutch Adjuster Screw Jam Nut to 72 – 120 in-lbs.
17. Squeeze the Clutch Lever 3 times to its maximum limits.
18. Move Clutch Cable Adjuster away from the Jam Nut to remove free play in the Clutch Lever. Adjust Clutch Cable free play until there is $\frac{1}{16}$ to $\frac{1}{8}$ inch gap between the Clutch Cable ferrule and Clutch Lever Bracket.
19. Tighten the Clutch Cable Adjuster Jam Nut. Slide the Rubber Boot over the Clutch Cable Adjuster.
20. Install the Primary Chain Adjuster with its fasteners and tighten.
21. Hang new Primary Chain Case Cover Gasket on Dowels.
22. Install the Outer Primary Chain Case Cover over the Primary Chain Case Cover Gasket.
23. Start thirteen $\frac{1}{4}$ - 20 SHCS with $\frac{1}{4}$ flat washers into the Outer Primary Chain Case Cover.

24. Torque the Outer Primary cover bolts to 108–120 in-lbs in the sequence below.

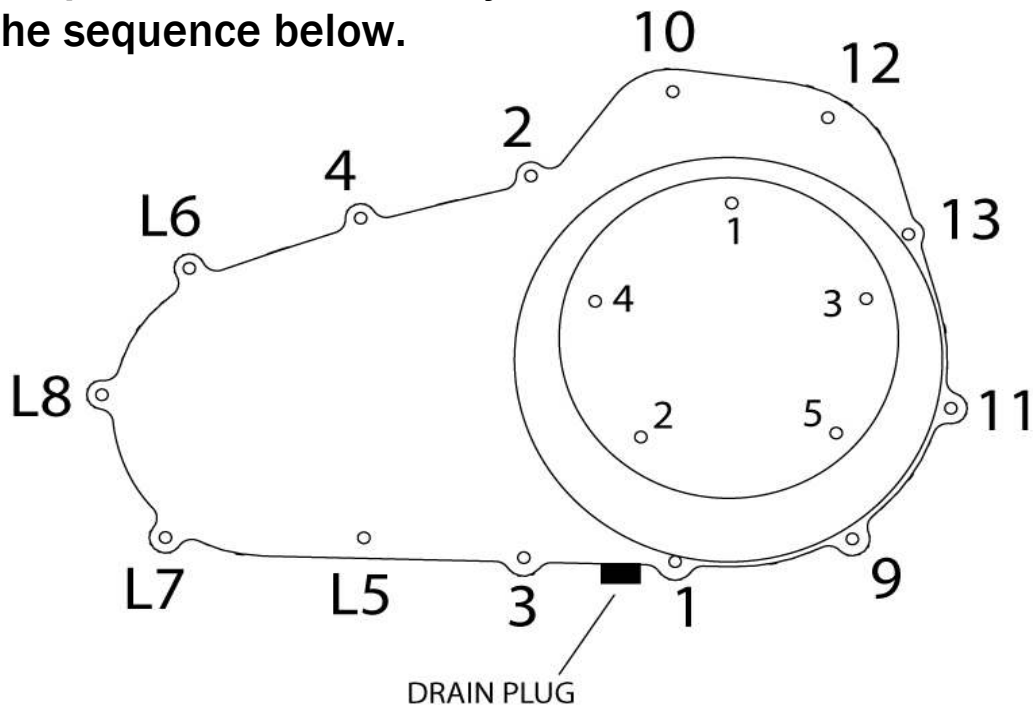

25. Apply thread sealant to the Drain Plug and reinstall.
26. Remove five $\frac{1}{4}$ - 20 torx head cap screws and the Clutch Inspection Cover.
27. Fill the Primary Chain case with 45 oz of Primary Chain case Lubricant.
28. Swab all lubricant from the Quad Ring groove in the Primary Chain Case Cover. Reinstall Quad Ring.
29. Using the five $\frac{1}{4}$ - 20 torx head cap screws replace the Clutch Inspection Cover. Torque to 84-108 in-lbs in the sequence above.
30. Reinstall the shift rod rubber.
31. Reinstall the Inner and Outer Shift Levers.
32. Reinstall the Front Drivers Footboard using the OEM fasteners.

MODIFICATION OF FRAME:

1. It will be necessary to cut the plastic Electrical Bracket along the white line to allow the drive support to fit up to the transmission.

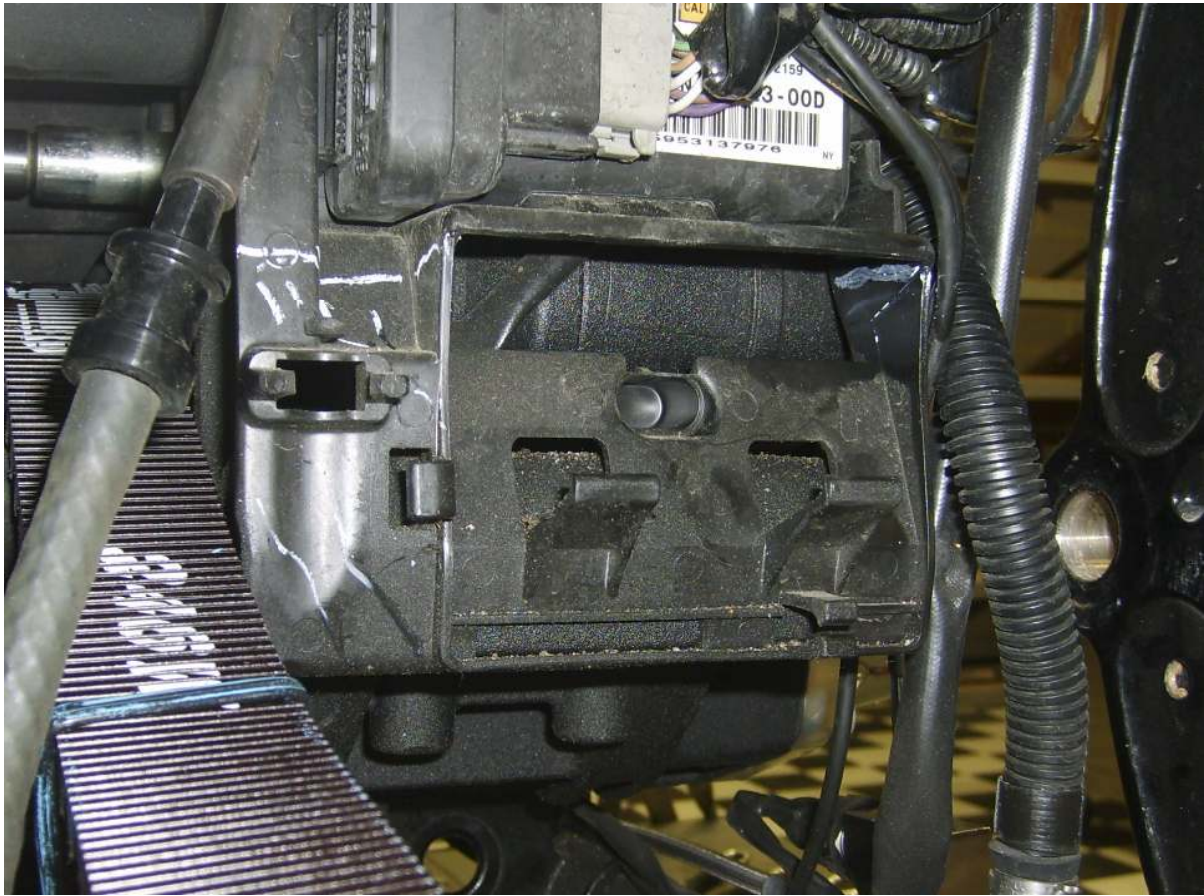

Picture before cutting.



Picture after cutting

Rear Suspension Unit Installation:

- 1. Place Suspension Unit using a jack behind prepared motorcycle.**
- 2. It will be necessary to remove oil drain hose from its fitting to install Drive Support.**
- 3. It may be necessary to loosen the front engine mount bolts in order to align the Drive Support.**
- 4. Slide Suspension Unit past the pivot shaft alignment for belt installation and reinstall oil drain hose.**
- 5. Install the front drive belt onto the Drive sprocket.**
- 6. Install new frame sleeves into each side of the frame.**
- 7. Install Rear Fork Pivot Shaft with OEM flat washer from left to right.**
- 8. Install nut and flat washer and leave loose.**
- 9. Note: Steps 9 and 10, 2000-2007 Only: Install the Upper Mount Plate at the rear with two 1/2 - 20 x 1 SHCS and nyloc nuts.**
- 10. Install two 3/8 - 16 x 2 SHCS thru the Upper Mount into frame and thread into the Upper Mount Plate using thread locking agent.**
- 11. 2008-Current Only: Using existing bolts install new ECM mount plate to rear of motorcycle frame so that it is pointing up and rearward. Install ECM using original nuts.**

Brake Line Installation:

- 1. Re-clamp the Wire Harness Clips that were previously used to clamp the Rear Brake Hose.**
- 2. Reinstall the Rear Stop Lamp Switch into the new Rear Brake Hose. Use proper thread sealant on the Rear Stop Lamp Switch.**
- 3. Route new Rear Brake Hose with the bent banjo fitting towards the Rear Brake Master Cylinder. The Rear Brake**

line will be to the inside of the frame at the Rear Brake Master Cylinder.

4. Using one Banjo Bolt and two Crush Washers. Install the bent banjo fitting onto the Rear Master Cylinder. Torque to specification.
5. Route the Rear Brake Hose along the Frame.
6. Use Cable Ties to hold the Rear Brake Hose to the Frame.
7. Reinstall the two wiring connectors onto the Rear Stop Lamp Switch.
8. Route the Rear Brake Hose to the inside of the Frame and onto the Distribution Block.
9. Using the second Banjo Bolt and two Crush Washers, install the straight banjo fitting onto the Distribution Block.
10. Using Cable Ties, secure the Rear Brake Hose to the Frame.

Brake bleeding procedure:

1. Using correct brake fluid, fill Rear Brake Master Cylinder Reservoir.
2. Using a vacuum bleeder, follow this procedure **carefully**.

Standard Brakes

- a. Bleed both rear upper bleed valves

Performance Brakes

- a. Rear caliper rear bleed valves outsides first then insides on each side.
- b. Rear caliper front bleed valves outsides first then inside on each side.
3. Hand bleed the system using the above sequence. Until all air is removed from the lines.
4. Allow the bike to set for a minimum of 20 minutes and recheck the pedal travel.

5. If there is excessive pedal travel on the first pump, repeat steps 3 and 4.



Frame Mount Installation:

1. Install the left frame mount using three 5/16 - 18 SHCS.
2. Thread one into the rear tapped hole in the motorcycle frame. Use thread locking agent.
3. Insert the other two into the upper and lower tabs on the suspension unit. NOTE: It may be necessary to loosen the 8 bolts that hold the rear differential support to the suspension trays in order to align the frame mounts.
4. Using two 5/16 flat washers and two 5/16 nyloc nuts tighten the three SHCS.
5. Repeat for the right side.

Gravel Pan Installation:

1. Install the Gravel Pan under the tab on the Lower Rear Mount with three 1/4 - 20 x 3/4 HHCS six flat washers and three nyloc nuts.
2. Raise the front of the Gravel Pan and secure with two strap clamps and two 1/4 - 20 x 3/4 HHCS, four flat washers and two nyloc nuts.

3. In the center use the two middle mounts, four 1/4 – 20 x 3/4 HHCS, eight flat washers and four nyloc nuts.
Align and tighten all fasteners.

Exhaust Mount Installation:

1. Place the Left Exhaust Mount against the left side of the Body Frame.
2. Using the lower holes. Install three 5/16 – 18 x 1 1/4 HHCS and three 5/16 flat washers thru the Exhaust Mount and the Body Frame from the outside in.
3. Install Trailer Hitch now if equipped.

NOTE: If trailer hitch is installed it will be necessary to trim the bottom center of the body for clearance of the tongue.

4. Loosely install three 5/16 flat washers and three 5/16 – 18 nyloc nuts.
5. Install the right side with the same procedure.

Exhaust Head Pipe Installation:

1. Install the Front Exhaust Bracket onto the frame with two 5/16 – 18 x 1 HHCS and two 5/16 flat washers.
2. Install new Exhaust Gaskets.
3. Loosely install the new Front and Rear Cylinder Head Pipes.
4. Loosely install two exhaust clamps onto the exhaust mount.
5. Snug up the clamps then snug up the exhaust studs making sure everything is aligned. Tighten in the same order.
6. Install O² sensors if equipped.

Exhaust Tailpipe and Muffler Installation:

- 1. Place one muffler clamp onto each Rear Exhaust Pipe.**
- 2. Slide the Right Rear Tailpipe onto the Upper Exhaust Pipe.**
- 3. Slide the Left Rear Tailpipe onto the Lower Exhaust Pipe.**
- 4. Place one new Exhaust Clamp onto each of the Tailpipes for the mid mount and one on each muffler and slide the mufflers onto the Left and Right Tailpipes.**
Note: Insure there is a 1/2 inch air gap around the inner C.V. joint
- 5. Loosely install four 5/16 - 18 x 1 hex head cap screws with 5/16 flat washers into the mufflers.**
- 6. Tighten all clamps but leave the muffler bolts loose for vertical alignment later.**

Link to CSC Belt Tensioning Video:

<http://www.californiasidecar.com/support.html>

Setting up the Sonic Tension Meter:

1. Turn power on, Push Select then 1.
2. Using the charts below in Front and Rear belt tensioning push Mass then the numbers, Width and so on.
3. For the Rear belt push Select then 2. Reverse belt can be number 3 and so on.

Using the Sonic Tension Meter:

1. The microphone placement over the belt is critical.
 - a. The microphone should be in the middle of the belt width-wise.
 - b. The microphone should be equally in-between the two Sprockets.
 - c. The microphone should be between $\frac{1}{4}$ and $\frac{1}{2}$ an inch above or below the Belt.
2. Turn the Sonic Tension Meter on.
3. Ensure that the correct setting is displayed on the LCD screen.
4. Push MEASURE then gently tap the Belt with a wrench while holding the microphone in the correct position. A measurement in Lbs. of single span tension should display. If not continue tightening the Belt until a reading is displayed.
5. In noisy environments the Sonic Tension Meter may display errant numbers. If so use in a quieter area.
6. Always take at least THREE readings of the Belt tension and average the THREE readings to determine the actual tension of the Belt.

Tensioning the Front Drive Belt:

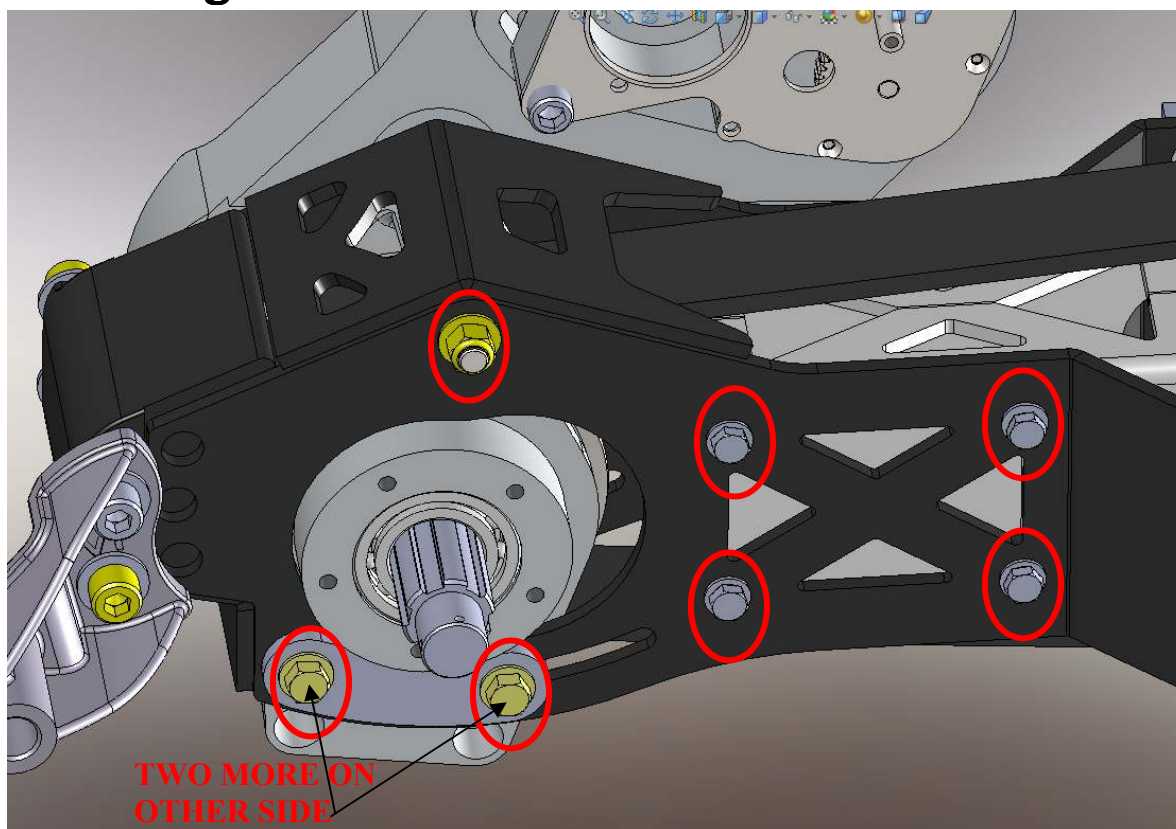

1. Loosen the four HHCS in the rear only on the left side. Next loosen the four clamping HHCS two per side and the one upper pivot shaft nyloc nut.
2. Tighten the Rear Drive Belt adjuster nuts until the slack is taken up on the Front Drive Belt.
3. Use the correct setting on the Sonic Tension Meter.

<u>2000 - 2006</u>	<u>2007 - CURRENT</u>
MASS 007.9 g/m	MASS 007.9 g/m
WIDTH 028.0 mm/R	WIDTH 028.0 mm/R
SPAN 0331 mm	SPAN 0341 mm
4. Check Front Drive Belt tension.
Both Belts: 130 - 150 lbs. single span tension.
5. Once the correct belt tension is achieved tighten all fasteners previously loosened in step 1. Eight HHCS and one nyloc nut.
6. Verify belt tension.
7. If incorrect start back at step 1. If correct proceed to Rear Belt Tensioning.

Tensioning the Rear Drive Belt:

1. See diagram below.

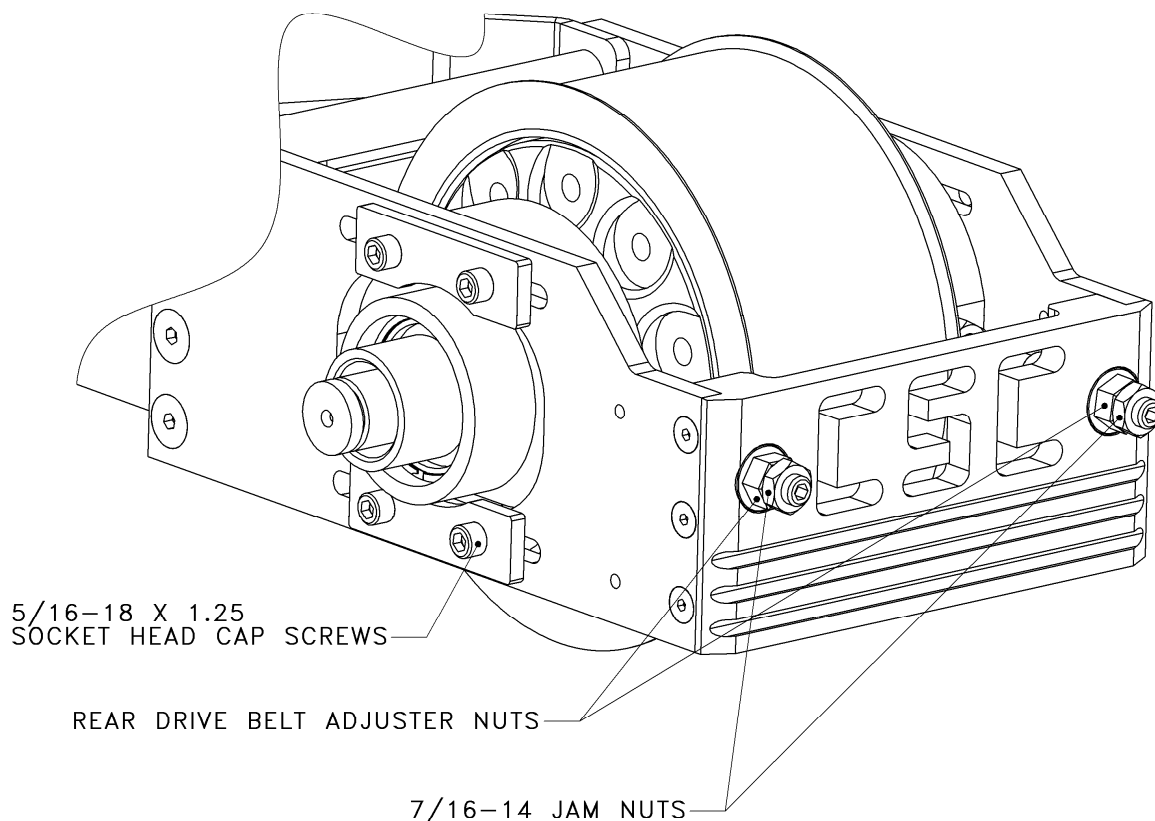

2. Tighten the Rear Drive Belt Adjuster nuts until the slack is taken up on the Rear Drive Belt.
3. Use the correct setting on the Sonic Tension Meter.
MASS 007.9 g/m
WIDTH 050.0 mm/R
SPAN 0442 mm
4. Check Rear Drive Belt tension.
5. 50mm belt: 130 - 150 lbs. of single span tension.
6. In the next step you are going to run the engine. Please be aware of the safety of all those involved. Make sure you have at least two lug nuts on each rotor and that they are tight.
7. To finish alignment, the belt must have at least 0.040in clearance between edge of belt and fence on front Rear Drive Sprocket. Check this by starting the engine and

placing it in second gear and simply let the engine idle. Checking the alignment by eye and centering the belt as it spins. If belt has correct clearance, go to **step 9**. If it does not have clearance, proceed to **step 8**.

8. Use the Left and Right Rear Drive Belt Adjuster Nuts to align belt in order to achieve the necessary belt clearance. NOTE: The belt will always track to the side of the sprocket that is the loosest. Repeat step 4.
9. Once the correct belt alignment and single span tension is achieved, tighten the eight 5/16 - 18 x 1 1/4 SHCS that go into the Carrier Bearing Support Housings.
10. Install two 7/16 - 14 hex jam nuts onto the Rear Drive Belt Tensioning Studs and tighten.
11. Verify belt tension and alignment.
12. If all is correct move on to next step. If not loosen clamping bolts and return to step 4.
13. Install left frame mount now the same as the right.

Service Limits on Drive Belts:

1. Service limit on the Front Drive Belt is 130 - 150 lbs.
2. Service limit on the Rear Drive Belt is 130 - 150 lbs.

Suspension Setup:

Use this chart to select the correct spring preload. Rotate the adjuster nut on the shock until the spring is set to the desired length. Now tighten the set screw on the adjuster nut or tighten the lock nut on the fully adjustable shock.

Load: Typical weight the customer adds to the stock trike. This includes riders, luggage, and weight of a trailer tongue.

When in doubt assume a higher weight than actual.

Length: Suggested length the spring should be adjusted to with the suspension completely unloaded and the preloader adjusted all the way out.

VOLUSIA								
STANDARD SHOCK								
	LOAD	LENGTH		LOAD	LENGTH		LOAD	LENGTH
250 LB/IN SPRING	100	11 1/8	300 LB/IN SPRING	100	11 1/4	325 LB/IN SPRING	100	11 5/16
	200	10 7/8		200	11		200	11 1/8
	300	10 9/16		300	11 13/16		300	10 7/8
	400	10 1/4		400	10 1/2		400	10 5/8
				500	10 3/8		500	10 7/16
				600	10 1/8		600	10 1/4
							650	10 1/8
ADJUSTABLE SHOCK								
	LOAD	LENGTH		LOAD	LENGTH		LOAD	LENGTH
250 LB/IN SPRING	100	10 5/8	300 LB/IN SPRING	100	10 13/16	325 LB/IN SPRING	100	10 15/16
	200	10 3/8		200	10 5/8		200	10 3/4
	300	10 1/16		300	10 3/8		300	10 1/2
	400	9 3/4		400	10 1/8		400	10 1/4
				500	9 7/8		500	10
							600	9 7/8
							650	9 5/8

- 1. Install preload adjuster now if equipped. Refer to separate installation instructions.**
- 2. Install Fully Adjustable shock adjuster now if equipped. Refer to separate installation instructions.**

These lengths are only estimates. If you would like to confirm a correct setting, load the completed trike to the customers typical riding situation and measure from the ground to the middle of the lower suspension plate. The center hole should be 5.75” – 6.25” from the ground.
Attention: This is the only suspension adjustment needed. All other settings are factory set and should not be tampered with. There is no need to remove trike from the lift to check camber, toe, or the drop links.

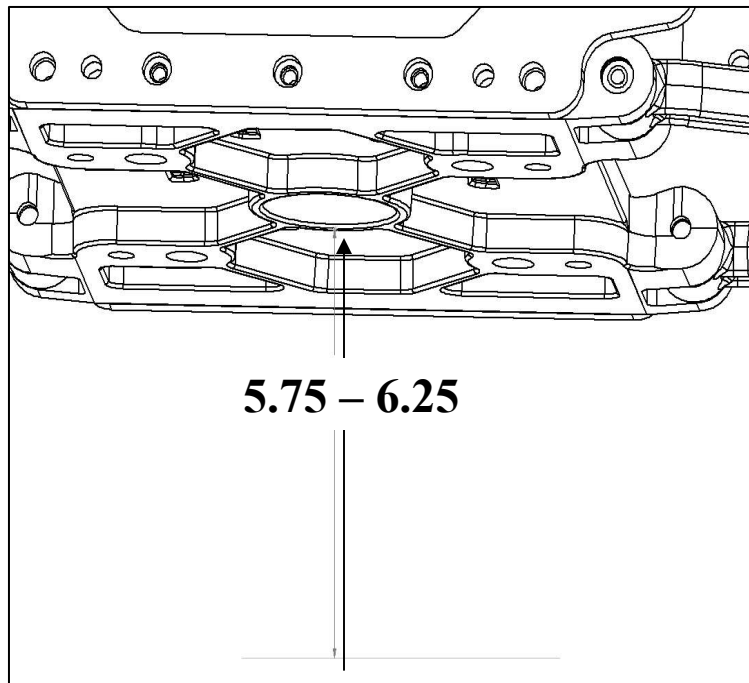

Trike Body installation:

1. If installing Electric Reverse or Ground Effects.

NOTE: 2000-2007: Install the controllers with two sided tape to Control mount plate.

NOTE: 2008 to Current: Install the controllers to the Upper Frame Mount with two sided tape and zip ties using slots provided.

Connect and route the wiring.

2. Lower the body onto the trike with the front of the body pointing downward until it comes to rest onto the upper tray and body frame.

Trike Body alignment:

1. The Trike Body can move left, right, forward, backward, up, down, and angled. Shimming with the provided 1/4 and 1/8 Rubber Washers may be required to get the Trike Body into alignment.
2. First raise the front of the body to obtain the vertical location around the passenger foot peg location.

3. Then slide the body front to back to get the horizontal location.
4. With the body temporarily held into place, raise the adjustable 90° body support brackets until they seat against the body's inner liner.
5. Tighten the two 5/16 – 18 x 3/4 hex head cap screws and two 5/16 – 18 nyloc nuts on the Adjustable 90° Support Brackets.
6. Center the Trike Body left to right with the tires and the mufflers.

Securing the trike body:

1. Using a 5/16 twist drill, drill up through the Adjustable 90° Body Support Brackets.
Note: A small section of Trike Body Carpet has not been glued at the location of the Trike Body Frame mounting tabs to allow removal of the bolts used in shipping, and installation of the Trike Body mounting hardware. The predrilled bolt holes may need to be enlarged or relocated for Trike Body attachment to the Trike Body Frame mounting tabs. If relocation is necessary, the preexisting holes will need to be sealed with silicone sealant.
2. Using a 5/16 twist drill, drill up through the Trike Body Frame mounting tabs.
3. Insert two 5/16–18 x 1 1/4 HHCS, two 5/16 x 1 1/2 fender washers, and rubber washers if necessary through the holes drilled in step 3.
4. Insert two 5/16–18 x 1 1/4 HHCS and two 5/16 x 1 1/2 fender washers through the adjustable 90° body support brackets.

5. Install four 5/16-18 nyloc nuts and four 5/16 flat washers onto the four 5/16-18 x 1 1/4 HHCS and tighten.
6. Re-align the Mufflers into the Trike Body cutout and tighten hardware.
7. Install Passenger peg mounts with a 3/8-16 x 1 BHSCS into the frame. Install OEM peg spacer using a 3/8 - 16 X 2 1/4 SHCS thru the passenger peg mount and thread into the passenger peg clamp that hooks behind the frame.
8. Reinstall the peg in its new location using the OEM hardware.
9. Repeat for the other side.
10. If trike is equipped with a trailer hitch body must be notched to clear tongue.

Reassembly of the motorcycle:

1. Replace the 15 AMP "lights" fuse with the 20 AMP fuse provided.
2. Connect Body Wiring Harness connector under the Frame to the Rear Fender Wiring Harness Connector
3. Connect the red wire with Fuse Holder to the Positive Battery terminal.
4. Reconnect the negative battery terminal and the new white wire from the Trike Body Wiring Harness.
5. Replace the Seat and 1/4 - 20 Phillips head screw.

Final Reassembly of the motorcycle:

- 1. Install the Wheel Spacers with the flat surface towards the Brake Rotor if provided. (only with 9-spoke wheels)**
- 2. Reinstall the wheel and tire assemblies with ten m12 x 1.5 ET conical lug nuts. Torque to 65 FT-LBS.**

Refer to the Maintenance Schedule on p. 4 for details regarding future service inspections and maintenance.

**From all of us at California Sidecar.
Enjoy the ride.**

