

DAYTONA BY TRIKE

ABS HARDWARE KIT LIST 2009-CURRENT

1.) KIT

- | | | |
|--------------------------|----------------|--------------------------------------|
| <input type="checkbox"/> | 1 - ABS-0005 | SENSOR, ABS (INCLUDES 2 JAM NUTS) |
| <input type="checkbox"/> | 1 - ABS-58962 | BRACKET, SENSOR, ABS |
| <input type="checkbox"/> | 1 - ABS-56085 | MOUNT, TRIGGER ROTOR, ABS |
| <input type="checkbox"/> | 1 - ABS-0005-1 | ROTOR, TRIGGER, 40 POLE , MAGNET |
| <input type="checkbox"/> | 1 - ABS-72635 | BRAKE LINE, 26", CLEAR, DAYTONA, ABS |
| <input type="checkbox"/> | 1 - FST-72340 | 1/4-20 X 3/4 FHSCS |
| <input type="checkbox"/> | 5 - FST-23207 | 8-32 X 1/2 BHSCS, SS |
| <input type="checkbox"/> | 2 - FST-23122 | 10-24 X 3/8 BHSCS, SS |
| <input type="checkbox"/> | 1 - FST-21646 | 1/8 X 3/8 DOWEL PIN, SS |
| <input type="checkbox"/> | 4 - BRK-0010 | WASHER, CRUSH |
| <input type="checkbox"/> | 1 - BRK-0008 | BOLT, BANJO |

**ALL ORDERS ARE DOUBLE
CHECKED TO ELIMINATE
SHIPPING ERRORS.**

FILLED BY: _____

CHECKED & PACKED BY: _____

For installation assistance, call Parts & Technical support @ 434.263.8866

Warnings and considerations:

- 1.Disclaimer** - These instructions assume a level of understanding of motorcycle repair and maintenance beyond that of a “beginner” and/or “novice” and California Sidecar cannot be liable for an installer’s failure to understand or follow these instructions as written. Likewise, California Sidecar cannot be responsible if any of the steps are omitted or shortcuts are taken, or parts other than those supplied by California Sidecar are used.
- 2.“WARNINGS”** are all printed in bold type and capitalized. They mean to use extreme care in a given step so as not to damage the part, motorcycle, and/or yourself.
- 3.Always** wear safety glasses when using hand and/or power tools.
- 4.**When working in and around the fuel system, **always** work in a well-ventilated area, free from sparks and open flames.
- 5.**All directional references to the “right side” and the “left side” are as you were seated on the motorcycle.
- 6.**All directional references to “forward” mean to the front of the motorcycle while “back” means the rear of the motorcycle unless otherwise stated.

- 1. Do not remove either brake line or drain fluid until stated below.**
- 2. Remove caliper from caliper bracket and hang it with a zip tie.**
- 3. Finish disassembly, Front belt installation, and Rear suspension installation. Refer back at step 9 Brake line installation.**
- 4. Install rear brake line to distribution block with banjo bolt and two crush washers.**
- 5. With a helper have them depress the rear brake pedal about 1/3 of the way down and hold it there the hole process.**
- 6. With pressure on the pedal remove the rear brake line going to the caliper from the A.B.S. module.**
- 7. Install with two new crush washers the CSC rear brake line reusing the banjo bolt.**
- 8. Once the banjo bolt is tight have your helper depress the brake pedal fully. This will keep any air from entering the A.B.S. Module.**
- 9. We recommend that you only hand bleed the system.**
- 10. Brake bleeding procedure will be the same.**
- 11. If any air gets in the A.B.S. Module you will have to have a Harley Davidson Dealer bleed the brakes using there Digital Tech.**
- 12. After the Electric Reverse is installed now install the mount, trigger rotor, ABS.**
- 13. Using five 8-32 x 1/2 BHSCS secure the mount to the lower reverse sprocket as shown.**
- 14. Using two 10-24 x 3/8 BHSCS secure the bracket, sensor, ABS to the reverse housing as shown.**

- 15. Install one jam nut on the sensor then into its bracket then adjust sensor to have a .050 of an inch air gap and lock into place with the other jam nut.**
- 16. Route wire up to the ABS Module and plug in. Secure wires with a zip tie.**

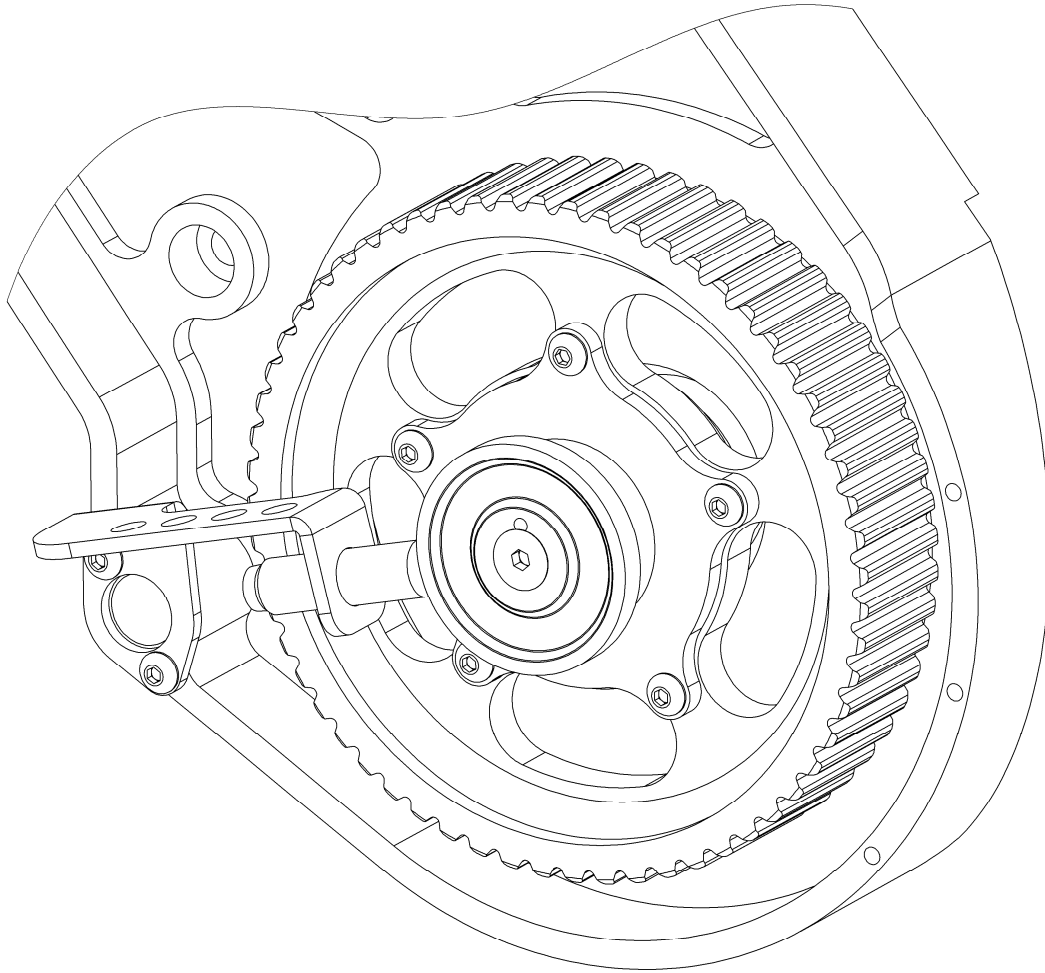

**From all of us at California Sidecar.
Enjoy the ride!**