



Auxiliary Fuel Tank Installation Instructions

Revised 1 - 09

Parts List

- 1 – Fuel Tank, 3.4 gal
 - 1 – 90° brass elbow w/ check valve, ¼ barb x 1/8 NPT (installed)
 - 2 – 6-32 x 3/8 truss Phillips machine screw
 - 2 – #6 SAE flat washer zinc
- 1 – Fuel Tank Mount (installed)
 - 3 – ¼ -20 x ½ flanged button head socket cap screw(installed)
 - 4 – Tank Mount Frame Clamp, rubber cushioned
 - 4 – ¼-20 x 5/8 button head socket cap screw
 - 4 – ¼-20 Nyloc nut
 - 4 – ¼ flat washer
 - 1 – 1-3/4” x 1-3/4” neoprene strip, adhesive backed
- 1 – Driveshaft Loop
 - 2 – ¼ flat washer
 - 2 – ¼-20 Nyloc nut
- 1 – Relay Box Clamp Bracket
 - 1 – 10-32 x 5/8 truss Phillips machine screw
 - 1 – 10-32 Nyloc nut
 - 1 – Relay Box Clamp Vinyl Coated Strap
 - 1 – ¼ -20 x ½ flanged button head socket cap screw
 - 1 – ¼-20 Nyloc nut
- 1 – Fuel Line, Braided Stainless Steel
 - 1 – 90° adapter 7/8” JIC - ½” NPT
 - 1 – 7/8-14 hex nut
 - 2 – Stat-O-Seal
 - 2 – Crush washer, 7/8 x 1-3/8 x .031
 - 1 – 90° bulkhead fitting
- 1 – Vapor Return Line Hose, 74”
- 1 – hose clamp
- 1 – Button tie
- 1 – Nylon “T” Fitting, ¼ barb
- 1 – Hole Locating Pattern, fiberglass

For installation assistance, call Parts & Service @ 434.263.8866

Warnings and considerations:

- 1. Disclaimer** - These instructions assume a level of understanding of motorcycle repair and maintenance beyond that of a “beginner” and/or “novice” and California Sidecar cannot be liable for an installer’s failure to understand or follow these instructions as written. Likewise, California Sidecar cannot be responsible if any of the steps are omitted or shortcuts are taken, or parts other than those supplied by California Sidecar are used.
- 2. “WARNINGS”** are all printed in bold type and capitalized. They mean to use extreme care in a given step so as not to damage the part, motorcycle, and/or yourself.
- 3. Always** wear safety glasses when using hand and/or power tools.
- 4. All** directional references to the “right side” and the “left side” are as you were seated on the motorcycle.
- 5. All** directional references to “forward” mean to the front of the motorcycle while “back” means the rear of the motorcycle unless otherwise stated.

Installation of the Auxiliary Fuel Tank in conjunction with a complete Cobra Trike Kit installation will begin before Section 5, step 1 – Reassembly of Motorcycle.

Refer to **Section 4 – Disassembly of Motorcycle** before beginning the Auxiliary Fuel Tank installation.
*If the Auxiliary Fuel Tank is being installed on a completed Cobra Trike conversion, refer to **Section 4, step 39-44** of the Cobra Trike Kit Installation Instructions.

When working in and around the fuel system, always work in a well-ventilated area, free from sparks and open flames.

1. Remove two mounting screws that connect relay box to the inner fender. (top)
2. Remove three relays and two solenoids from plastic holder on left side of inner fender.
3. Remove three rivets from the mounting bracket that holds the power control relays on the left side of the inner fender. Removed in Step 2.
4. Remove two bolts that hold inner fender. Cut zip tie on left side and remove inner fender.
5. Drain all fuel from tank.
6. Remove locking ring of fuel pump using Honda tool #07ZMA-MCAA201.
7. Remove base ring and remove fuel pump.

Warning: Use caution when removing pump from tank to avoid damaging pump.

Warning: Use caution when drilling in steps 8-11. Ensure that the drill is perpendicular to bottom of tank.

8. Wipe any excess fuel from tank. Place the supplied fiberglass Hole Locating Pattern into position on right rear of OEM fuel tank. The template will conform to lower right rear bulge on tank.
9. Locate hole in template and drill 1/8" pilot hole in OEM fuel tank. Remove template and discard.
10. Using a 3/8" drill bit enlarge 1/8" pilot hole to 3/8".
11. Using a 7/8" or 22.5 mm knock out punch, enlarge the 3/8" hole once more in the OEM fuel tank. Deburr the hole.
12. Install 90° bulkhead fitting through hole in OEM fuel tank using sequence of crush washers and Stat-O-Seals illustrated in Figure 1. Tighten nut inside the tank.

NOTE: You MUST hold bulkhead fitting while tightening nut.

FIGURE 1.

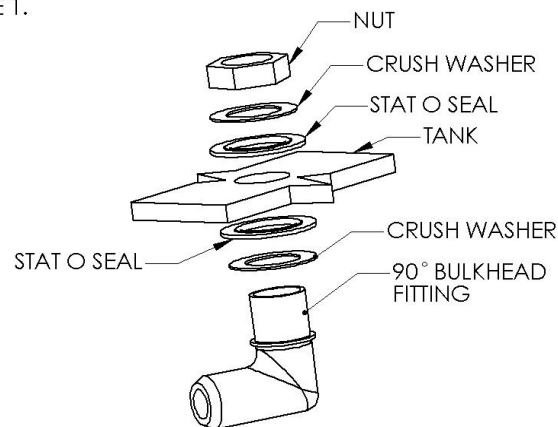

13. Place two tank mount frame clamps on the left and right side of the motorcycle frame just above saddlebag crash guard mounts.
14. Apply 1-3/4" x 1-3/4" neoprene strip to front tab of tank mount. Slide auxiliary tank mount into position by inserting front tab of auxiliary fuel tank mount into slot where inner fender was removed, located on the back of the battery box or main tank strap.
15. Install four 1/4-20 x 5/8 button head socket cap screws through rubber insulated strap mounts and through fuel tank mounting bracket. Make sure the auxiliary fuel tank is all the way forward. Then tighten all four fasteners.
16. Connect the braided steel fuel feed line to the 90° bulkhead fitting, but do not tighten fuel feed line coupler yet. Route the line to the left side of bike then back to auxiliary fuel tank.
17. Install 90° adapter 7/8" JIC-1/2 NPT fitting into auxiliary fuel tank. Be sure to use Teflon tape on the threads. **Do not overtighten.**
18. Connect the fuel feed line to the 90° adapter installed in auxiliary fuel tank.
19. Tighten the fuel feed line couplers on both 90° fittings, ensuring there are no kinks or twists in the line.
20. Wipe out tank with a clean cloth to eliminate drilling chips and dirt.
21. Add fuel to OEM tank and check all fittings thoroughly for any leaks.
22. Reinstall fuel pump in reverse order as it was

removed in Steps 5-6.

23. Install two rubber bumpers taken from the saddlebag sub frame and install on cross over tube between auxiliary fuel tank and frame cross over tube.
24. Install solenoid and plastic relay holder to left side of auxiliary fuel tank with two 6-32 x 3/8 truss head Phillips machine screws with washers and tighten screws.
25. Refer to **Figure 3**. Place relay box, right side down with tab between OEM fuel tank and auxiliary fuel tank.
26. Install relay box clamp bracket to frame cross over tube and fasten to upper relay block and tighten all fasteners.
27. Remove the top shelter per Honda Service Manual.
28. Refer to **Figure 3**. Route vapor return line forward along the right side of bike until you reach the EVAP canister No. 1 Hose in front of the splash tray that surrounds the filler neck. Refer to page 1-40 of Honda Service Manual.
29. Cut the EVAP canister No. 1 Hose approximately 1" back from loop on left side of splash tray. Refer to **Figure 2** taken from Honda Service Manual p. 1-40. Install nylon "T" fitting between two sections of No. 1 Hose.

Figure 2. (taken from Honda Service Manual p. 1-40)

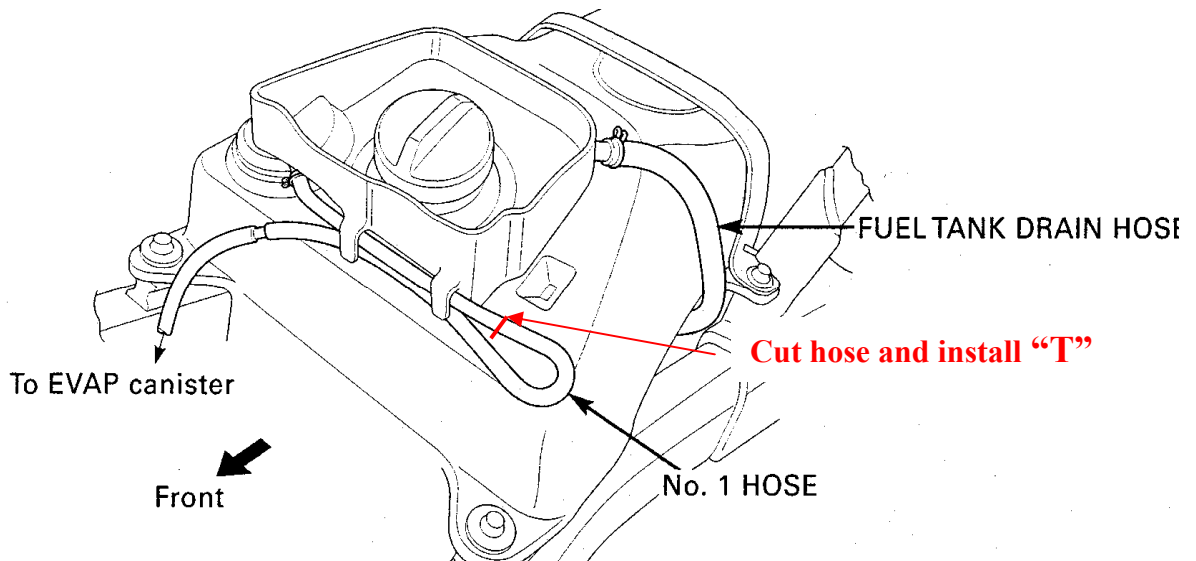

- 30. Connect vapor return line to the nylon "T" fitting.
- 31. Route vapor return line along right side of frame up to the top trunk leaving an 11" loop to be tie rapped to front of trunk down to the brass fitting. Refer to **Figure 3**. Cut vapor return line to length and install hose clamp. Drill $\frac{1}{4}$ hole approx. 2" from the center of the molded knob on the front of the trunk (right side).

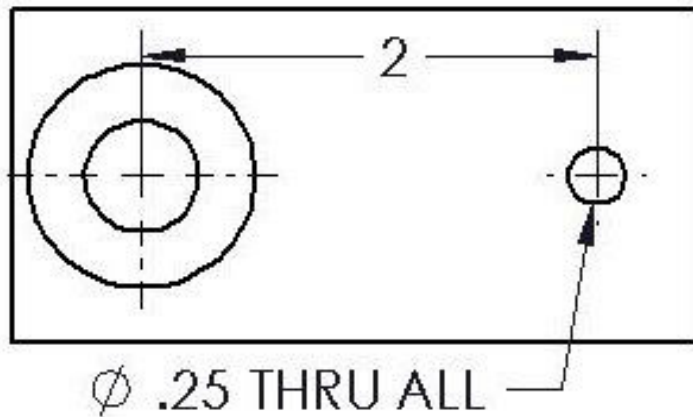

32. Install top shelter in reverse order it was removed. Make sure the vapor return line is not pinched after installing top shelter.
33. Install driveshaft loop when installing driveshaft and tighten the two $\frac{1}{4}$ - 20 nyloc nuts with $\frac{1}{4}$ flat washers.

NOTE: The Auxiliary Fuel Tank will fill and drain directly off the OEM fuel tank. When filling the tanks, there may be a slight delay in the transfer of fuel from the OEM tank to the Auxiliary tank. Allow the fuel to migrate to ensure a complete fill-up.

**From all of us at California Sidecar.
Enjoy the ride!**